



## INSTALLATION AND MAINTENANCE INSTRUCTIONS FOR LARGE DIAMETER MODEL M GAS VENTS (B-VENT)



These symbols on the nameplate means this product is listed by Underwriters Laboratories Inc. Listing No. MH7860

SIZES 16" (406MM) THROUGH 30" (760MM)

### GENERAL:

The Model M Gas Vent has been designed for use with gas burning Category 1 appliances. A Category 1 appliance operates with a non-positive vent static pressure and with vent temperature that avoids excessive condensate production in the vent.

The vent is interconnected with a slip fit and maintained with sheet metal screws. The vent is of a double-wall construction, with the inner flue of aluminum alloy (allowing rapid warm-up and better draft) and the outer casing of galvanized steel or galvalume steel.

### SAFETY:

**CAUTION: UL approval is based on using B-Vent components supplied by Metal-Fab, Inc. Performance may be affected and a safety hazard created if parts shown in these instructions are not used.**

1. This gas vent must maintain one-inch (25.4mm) clearance to combustibles for sizes 16-inch (406mm) through 24-inch (610mm). Two-inch (50.8mm) clearance to combustibles is required for sizes 26-inch (660mm) through 30-inch (760mm). DO NOT pack insulation or other materials around the vent.
2. Use of draft increasers are limited to the exhaust end of the vent system to maintain negative flue pressure.
3. Vent sizing is defined by tables in NFPA54 (ANSI Z223.1, 2002), or contact your Metal-Fab supplier. Install in accordance with these instructions and local code requirements.
4. Metal-Fab Type B Gas Vent and Fittings are to be used to vent approved gas appliances intended to burn **only** gas. Type B Vents are **NOT** to be used for the following:
  - A. Unlisted gas appliances
  - B. Incinerators
  - C. Recessed heaters
  - D. Conversion burners
  - E. Gas/oil burners
  - F. Any other appliance which may be readily converted to a solid or liquid fuel.
  - G. Any other appliance not intended to burn only gas.In areas where solid or liquid fuels are common, the vent location should be marked "For use with vented appliances burning only gas."
5. Locate vent as close as possible to the appliances to obtain maximum draft and to minimize connector pipe length.
6. Maintain a pitch or rise from appliance to vent on horizontal runs. Minimum rise is  $\frac{1}{4}$ " (6.4mm) to the foot.
7. A vent cap should be used on all installations to prevent back drafts and to keep out rain and debris.

8. Venting into an unlined masonry chimney may cause condensation. Install Type B Vent inside the chimney to prevent condensation.
9. Do not install vent outside except where it is absolutely necessary, and consult venting tables for proper design.
10. A gas vent support plate (MSP or MHS) is required if vertical height exceeds 30' (9144mm). Maximum of 30' (9144mm) between supports.
11. When running vent through insulated areas, care must be taken to prevent insulation from coming in contact with the vent. This may be done by nailing headers between joists through which vent is run, maintaining proper clearance to combustibles or by nailing a firestop on top of joists to prevent insulation from falling into boxed area.
12. Other than in single or two family dwellings, when gas vent extends through ceilings above the room with appliance(s), the vent is to be enclosed with materials having a fire rating equal to or greater than floor, ceiling, or roof.
13. It is not acceptable to penetrate the flue with screws except when attaching drafthood to appliance outlet or vent to single-wall connector.

### INSTALLATION:

The Type B Gas Vent sections and associated components are inserted one into another, then secured by sheet metal screws (#8 x  $\frac{1}{2}$ (13mm)) provided with each section (See **FIG. 1**).

1. Starting at the appliance outlet or top of drafthood, attach the first section or component. Secure with screws provided.

**NOTE:** Some appliances have the draft hood built into the appliance. For these, the gas vent attaches directly to the appliance outlet (See **FIG. 2**). If needed, a draft hood connector (MDC) is attached to the appliance outlet.

2. Continue upward with the gas vent. If a floor is to be penetrated, an MSP support plate or firestop is required. A field fabricated firestop is acceptable. To field fabricate a firestop, use a 26-gauge galvanized steel plate. Cut a hole slightly larger than the gas vent O.D. Position the firestop to maintain correct clearance to combustibles, then nail in place.

**NOTE:** A MSP is required for every 30 feet (9144mm) of vent stack to support the load.

3. When penetrating the roof, cut hole to maintain clearance to combustibles. The MF flashing and MSC storm collar are used to cover the hole in the roof. Terminate the vent using the MC cap. If vent is more than 6 feet above where it penetrates the roof, additional support is required. (See **FIG. 4**.)

**NOTE:** For Canadian installations, use cUL section, designated with a suffix G, on vent sections exposed to atmosphere.

- If the installation requires offsets, elbows are available. The inclined run (distance between elbows) must be supported every 5 feet (1542mm). Plumbers straps are acceptable. Total lateral and horizontal length shall not exceed 75 percent of total vertical height (See FIG. 3).
- It is acceptable to use a tee (MT) to multi-vent appliances into a common vent (See FIG. 3). A support plate (MSP), or other method, is required to support the gas vent weight above the tee. The horizontal run of the vent must be supported every 5 feet (1524mm). If no vent enters the bottom of the tee, a tee cap (MTC) is required to close the tee.

- Because the available lengths of vents may not meet your installation needs, an adjustable vent section (M18A) may be needed. The male end of the adjustable section engages in the same manner as the vent section, the female end opens to accept the male end of the vent section, then must be secured by tightening the clamp of the adjustable section (See FIG. 3).
- If the vent system must increase in size due to vent capacity, use an appropriate increaser (MI). The increaser is installed the same as any vent section.

This completes your installation. If assistance is required, contact your Metal-Fab supplier.

## MAINTENANCE:

Gas Vent System normally operates trouble free. Conduct a yearly inspection of the system, and replace any damaged parts.

**NOTE:** If extreme weather conditions occur, inspection of all exposed vent items is necessary. Replace any damaged part.

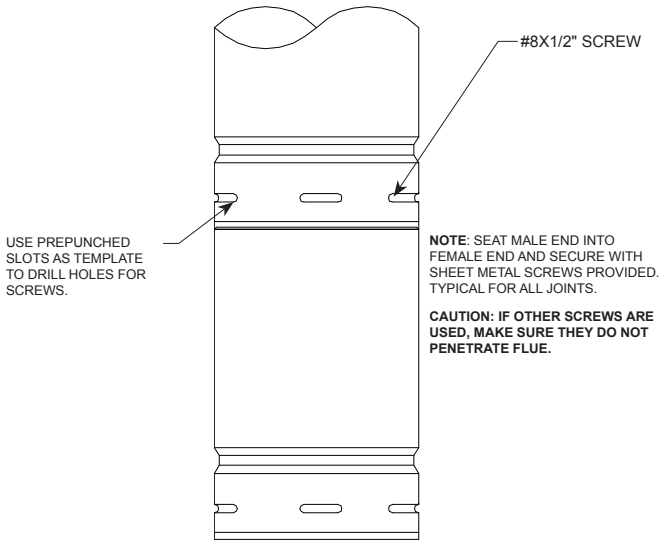

FIG. 1

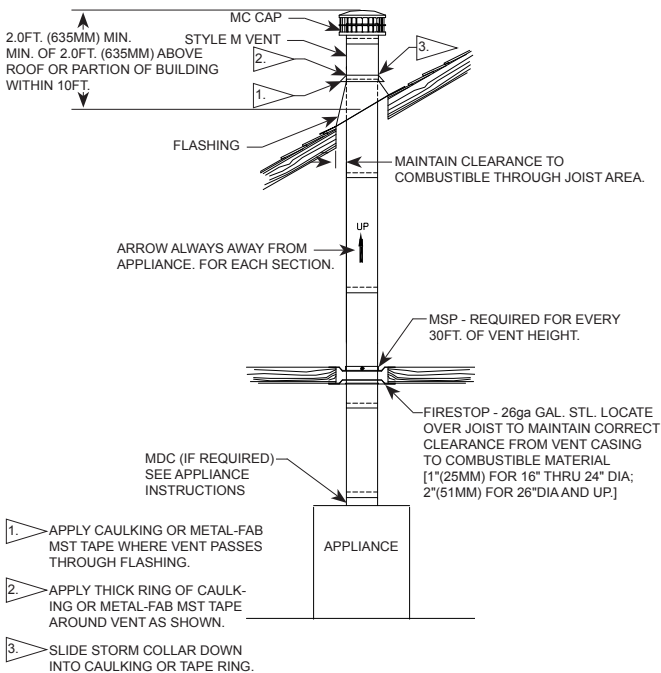

FIG. 2

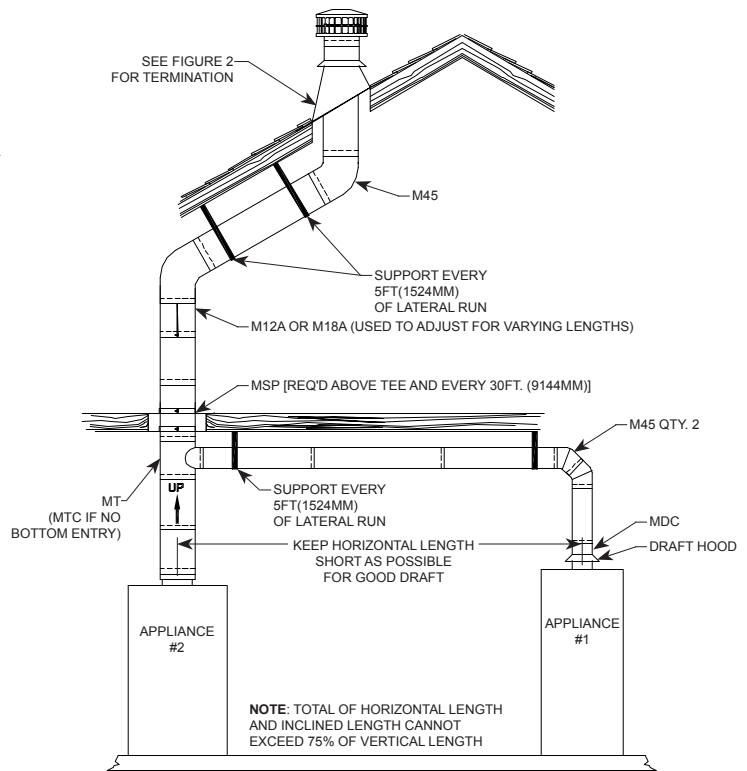

FIG. 3

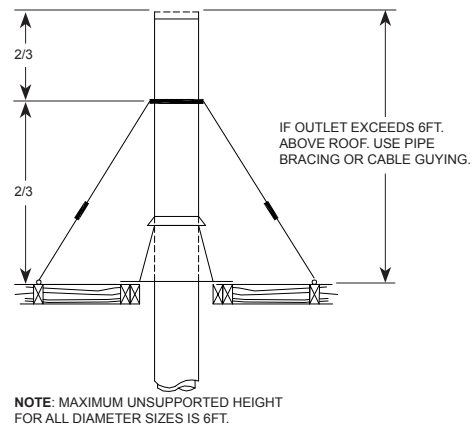

FIG. 4