

DESIGN MANUAL

**CORR/GUARD®**

**METAL-FAB<sup>®</sup> INC.**  
An OLYMPIC STEEL Company



Special Gas Vent 6" - 36" Diameters

# METAL-FAB

## CORR/GUARD® SPECIAL GAS VENT

Advanced design that cuts cost and time on the job!

### COMPLETE VENT LINE

- Including straight pipe lengths, adapters, elbows, tees, drain sections, support bands, flashing, caps and more. Single wall & double wall.
- 6" - 36" diameters; integral sleeve design.

### UNS S44735 STAINLESS STEEL FLUE (i.e. AL29-4C)

- Exceeds corrosion resistance requirements in UL1738 - Standard for Venting Systems for Gas-Burning Appliances, Categories II, III, and IV.

### SELECTION OF CASINGS

- Choose the most cost effective materials for the environment.
  - Aluminized Steel
  - 430 Stainless Steel
  - 304 Stainless Steel
  - 316 Stainless Steel

### LIMITED LIFETIME WARRANTY



*Integral Sleeve connections are formed to fit with precision at each connection.*



*All-welded construction provides liquid-tight performance and clean appearance.*



*Vee Band connectors are engineered for exact fit around flanges, providing a strong, liquid-tight connection.*

#### Also available: Corr/Guard® in 3" - 5" diameters

- Leak-proof Viton gasket
- One-step connection and snap-lock
- Single Wall and Double Wall

See Corr/Guard 3"-5" Brochure L2158 available at [www.metal-fabcommercial.com](http://www.metal-fabcommercial.com)

## TABLE OF CONTENTS

GENERAL INFORMATION .....	3
CODES & STANDARDS .....	3
PRODUCT INFORMATION .....	4
APPLICATION INFORMATION .....	5
COMPONENTS .....	6 - 27
DIMENSIONAL DATA/ WARRANTY .....	28-29

## GENERAL INFORMATION

Pertinent information is consolidated in this publication to assist you with application information, codes and standards, dimensional information, support requirements and other data of special interest. It is our goal to enable you to select the proper product to meet the requirements of your project confidently and efficiently.

For additional information you may contact us via:

**Web Site:** [www.metal-fabcommercial.com](http://www.metal-fabcommercial.com)

**Telephone:** 316-943-2351

**Toll Free Phone:** 800-835-2830

**Fax:** 316-771-4168

**E-mail:** [info@metal-fabcommercial.com](mailto:info@metal-fabcommercial.com)

Complete information for proper and safe installations is found in the Metal-Fab Installation Instructions. (Literature No. L2591)

This design manual contains data to assist in the proper selection, design, and layout of venting systems using Metal-Fab models:

- **FCS** – Double Wall Special Gas Vent
- **FCSSW** – Single Wall Special Gas Vent
- **FCS-1, FCS-2** – Double Wall Insulated Special Gas Vent
- **FCS-3** – Consult Factory

## CODES AND STANDARDS

Corr/Guard is listed to UL 1738, Standard for Venting Systems for Gas-Burning Appliances, Categories II, III, IV and ULC S636. These requirements cover venting systems intended for venting Category II, III, and IV gas-burning appliances as defined by the Standard for Gas-Fired Central Furnaces (except Direct Vent Central Furnaces), ANSI Z21.47 and the National Fuel Gas Code, NFPA 54. Venting systems covered by these requirements are intended to be used with Category II, III, and IV appliances that have been installed in accordance with NFPA 54, the ICC International Mechanical Code, the IAPMO Uniform Mechanical Code, and local codes.

Corr/Guard is listed to UL 641, Standard for Safety, Type L Low-Temperature Venting Systems. These requirements cover factory built vent piping and fittings constructed to provide venting systems for use with gas and liquid fuel-burning appliances that exhaust low-temperature flue gases and that are approved for use with Type L venting systems. The Type L low-temperature venting systems covered by these requirements are intended for installation in accordance with the National Fire Protection Association Standard for Chimneys, Fireplaces, Vents, and Solid-Fuel Burning Appliances, NFPA 211, the International Mechanical Code, and the Uniform Mechanical Code.

Note: 6" through 24" diameter Corr/Guard has a 3" vertical unenclosed clearance to combustibles when used in an L-Vent application. This UL 641 Listing does not allow installation within fully enclosed combustible construction.



MH26687

Corr/Guard vent material is UNS S44735 (i.e. AL29-4C) superferritic stainless steel. This vent is intended for use wherever appliance manufacturers specify superferritic stainless steel as the required vent material and, vent gas temperatures do not exceed those listed in the Metal-Fab Installation Instructions and the Application section of this manual.

Venting system design may be limited by appliance performance. Consult appliance installation instructions to determine limitations such as maximum horizontal length, maximum vertical height, elbow and offset limitations, and number of appliances permitted in a common vent.

Model FCSSW chimney liner systems, sizes 6" thru 36" diameter is intended for use in masonry chimneys used to vent Category II, III, or IV gas-fired appliances. FCSSW is suitable for installation in masonry chimneys having no clearance between combustible construction and the outer chimney surface. Model PSW chimney lining system, sizes 6" thru 36" diameter are intended for use in masonry chimneys used to vent gas fired appliances equipped with draft hoods; appliances equipped with draft hoods; appliances intended for use with Type B gas vents. PSW is suitable for installation in masonry chimneys having no clearance between combustible construction and the outer chimney surface.

# CORR/GUARD® PRODUCT INFORMATION

## Corr/Guard 6" – 12" Diameters To determine metric dimensions: multiply inches X 25.4

DESCRIPTION	DOUBLE WALL	SINGLE WALL
Max Operating Temperature	550° F (288 C)	550° F (288 C)
Max Operating Pressure	15" w.g.	15" w.g.
Clearance to Combustibles ENCLOSED – VERTICAL @550°F (288 C)	1"	Can Not Be Enclosed with Combustible Material
Clearance to Combustibles ENCLOSED – HORIZONTAL	Can Not Be Enclosed with Combustible Material	Can Not Be Enclosed with Combustible Material
Clearance to Combustibles UNENCLOSED HORZ. or VERT. @ 550° F (288 C)	1"	2"
JOINT CONNECTION	SLEEVED – P077 Sealant Required	SLEEVED – P077 Sealant Required
Flue Material Thickness	UNS S44735 (i.e. AL29-4C) 0.015"	UNS S44735 (i.e. AL29-4C) 0.015"
Casing Materials	Std- Aluminized Steel 0.018" Opt – 430 Stainless Steel 0.024" Opt – 304 Stainless Steel 0.024" Opt – 316 Stainless Steel 0.024"	Not Applicable

## Corr/Guard 14" – 24" Diameters To determine metric dimensions: multiply inches X 25.4

DESCRIPTION	DOUBLE WALL	SINGLE WALL
Max Operating Temperature	550° F (288 C)	550° F (288 C)
Max Operating Pressure	15" w.g.	15" w.g.
Clearance to Combustibles ENCLOSED – VERTICAL @550°F (288 C)	1"	Can Not Be Enclosed with Combustible Material
Clearance to Combustibles ENCLOSED – HORIZONTAL	Can Not Be Enclosed with Combustible Material	Can Not Be Enclosed with Combustible Material
Clearance to Combustibles UNENCLOSED HORZ. or VERT. @ 550° F (288 C)	14" – 18" = 2" 20" – 24" = 3"	14" – 18" = 3" 20" – 24" = 4"
JOINT CONNECTION	SLEEVED – P077 Sealant Required	SLEEVED – P077 Sealant Required
Flue Material Thickness	UNS S44735 (i.e. AL29-4C) 0.024	UNS S44735 (i.e. AL29-4C) 0.024
Casing Materials	Std- Aluminized Steel Opt – 430 Stainless Steel Opt – 304 Stainless Steel Opt – 316 Stainless Steel 0.024"	Not Applicable
Thickness		

## Corr/Guard 26" – 36" Diameters To determine metric dimensions: multiply inches X 25.4

DESCRIPTION	DOUBLE WALL	SINGLE WALL
Max Operating Temperature	550° F (288 C)	550° F (288 C)
Max Operating Pressure	15" w.g.	15" w.g.
Clearance to Combustibles ENCLOSED – VERTICAL @550°F (288 C)	2"	Can Not Be Enclosed with Combustible Material
Clearance to Combustibles ENCLOSED – HORIZONTAL	Can Not Be Enclosed with Combustible Material	Can Not Be Enclosed with Combustible Material
Clearance to Combustibles UNENCLOSED HORZ. or VERT. @ 550° F (288 C)	26" – 30" = 4" 32" – 36" = 5"	26" – 30" = 5" 32" – 36" = 6"
JOINT CONNECTION	SLEEVED – P077 Sealant Required	SLEEVED – P077 Sealant Required
Flue Material Thickness	UNS S44735 (i.e. AL29-4C) 0.035	UNS S44735 (i.e. AL29-4C) 0.035
Casing Materials	Std- Aluminized Steel Opt – 430 Stainless Steel Opt – 304 Stainless Steel Opt – 316 Stainless Steel 0.035"	Not Applicable
Thickness		

## DESIGN CONSIDERATIONS

When venting gas appliances always consult the appliance installation instructions. Horizontal runs, elbows, offsets, vertical height, may be limited by appliance performance specifications.

**Horizontal** runs must slope a minimum of ¼" : 12" (6mm-305mm). Neutral or negative pressure systems must slope upward – away from the appliance. Positive pressure within the vent may slope upward or downward. Provide for condensate drainage where required.

**Vertical** runs are directional-specific and must be properly supported. Supports are required above every offset to prevent vertical loading on elbows.

### NOTE:

For Additional Information  
See Corr/Guard Installation Instructions, No. L2591  
Available at: [www.metal-fabcommercial.com](http://www.metal-fabcommercial.com)

## SIDEWALL EXHAUST

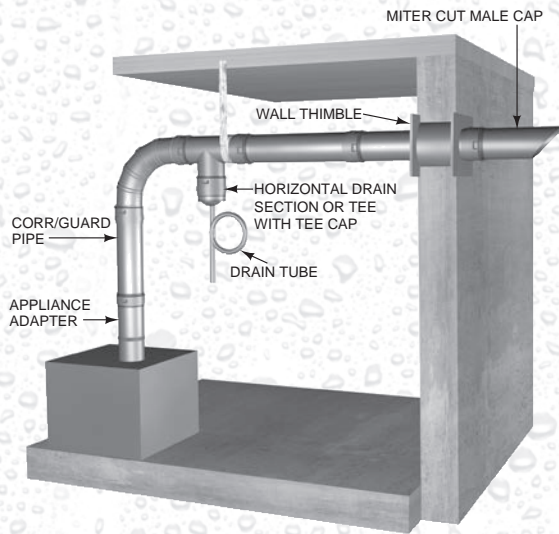

## MULTI-UNIT EXHAUST

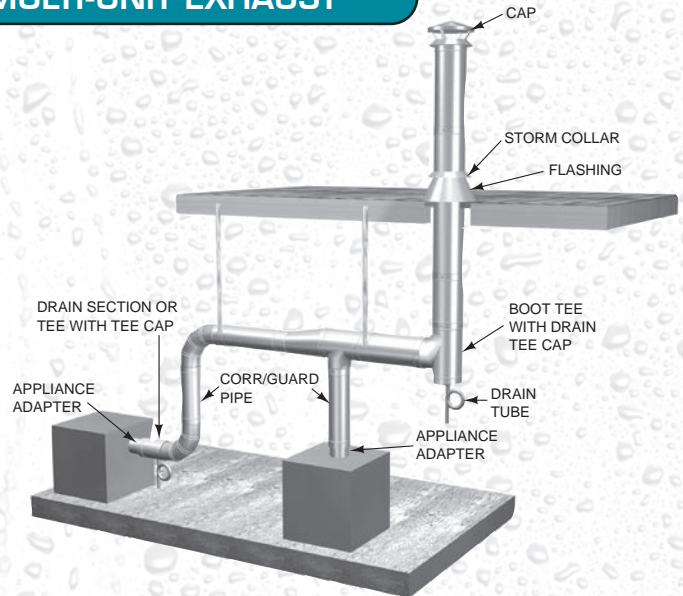

## COMPONENTS

Corr/Guard is identified as "FCSSW" and "FCS" designating the integral sleeve design incorporated in 6" – 36" diameters.

Corr/Guard is available in a multitude of material options to address your unique applications. To facilitate the ordering process we have a designated "CTO" code which allows you to **C**onfigure **I**n **O**rder. The CTO code consists of three (3) designators. The 1st identifies flue material; the 2nd identifies outer casing material, and the 3rd, (0, 1, 2 or 3) indicates the product is "air" or "ceramic fiber" insulated.

### Selections

FLUE	CASING	INSULATION
C – UNS S44735 (i.e. AL29-4C)	A – ALUMINIZED STEEL 3 – 430 STAINLESS 4 – 304 STAINLESS 6 – 316 STAINLESS	0 - Air Insulated 1 - Ceramic Insulated 2 - Ceramic Insulated 3 - Ceramic Insulated

### Example:

You have selected a 6" diameter pipe section, 36" in length, double wall construction, with a 430 stainless casing with ceramic fiber insulation. The part number is 6 (diameter)-FCS (sleeved Corr/Guard) 36" length. Additionally, you have selected the CTO code: C (UNS S44735 [i.e. AL29-4C] Stainless Flue) - 3 (430 Stainless Casing) -1 (Ceramic Insulated).

**The complete designation is: 6FCS36 – C31.**

## CORROSION RESISTANCE

Corr/Guard products are designed for use on today's highly efficient condensing appliances. UNS S44735 (i.e. AL29-4C), a Superferritic Stainless Steel was the first steel to successfully exceed the requirements of UL 1738, "Standard For Venting Systems For Gas-Burning Appliances, Categories II, III, and IV." It is considered the benchmark for condensing flue materials.

# FCS/FCSSW COMPONENTS 6" – 36" DIAMETERS

## SINGLE WALL BOILER ADAPTER (SBA)

Flow Resistance K = same as pipe.

6" - 24": A = 7" (178)

26" - 36": A = 6" (152)

Used to attach pipe to straight shank outlets. Attaches around exterior of collar. FCS SBA includes closure band. Not required on FCSSW.

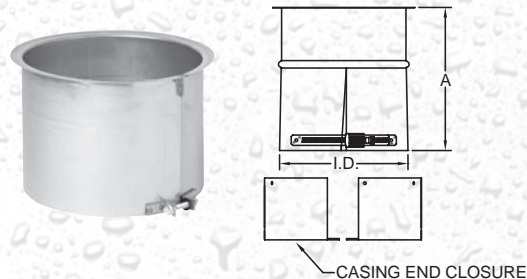

## SINGLE WALL BOILER ADAPTER – INSIDE (SBAI)

6" – 24" Diameters

Flow Resistance K = same as pipe.

Used on vertical outlets when appliance incorporates condensate drain.

**NOTE:** Not available above 24".



## REDUCER COLLAR (RC)

6" – 24" Diameters

Flow Resistance K = same as pipe.

A: Inlet Diameter

B: Component Length = 7"

C: Outlet Diameter

Used to attach pipe to an outlet source smaller than pipe diameter.

Specify dimensions when ordering.

**Example:** 8FCS7RC



## FEMALE FLANGE CONNECTOR (FFC)

6" – 24" Diameters

Flow Resistance K = same as pipe.

Used to transition from FCS to CG

**NOTE:** Not available in 7" & 9" diameters.



## MALE FLANGE CONNECTOR (MFC)

6" – 24" Diameters

Flow resistance K = same as pipe.

Used to transition from CG to FCS

**NOTE:** Not available in 7" & 9" diameters.



## FEMALE TO FEMALE ADAPTER (DFA)

6" – 24" Diameters

Used to change direction of slope.

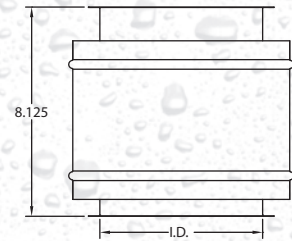

## MALE TO MALE ADAPTER (DMA)

6" – 24" Diameters

Used to change direction of slope.

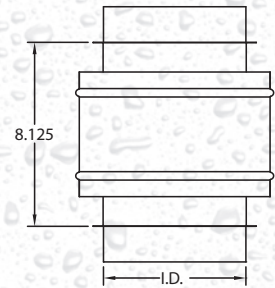

## BLAST GATE (BG)

6" – 12" Diameters

Used for balancing pressures in a common vent system.

**Note:** Available in single wall only.

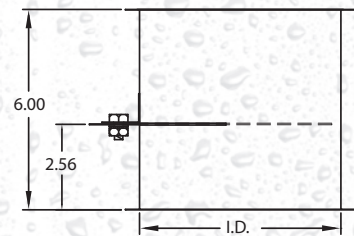

## CASING END CLOSURE (CEC)

Used as an end cover when transitioning from single wall to double wall construction. Attaches to casing with sheet metal screws.

**Note:** 26" - 36" Casing End Closure clamps around casing bead.

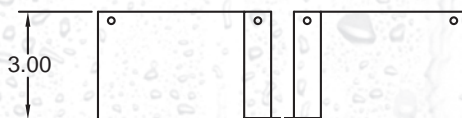

6" – 24" Diameters



26" – 36" Diameters

# FCS/FCSSW COMPONENTS 6" – 36" DIAMETERS

## PIPE LENGTHS

Flow Resistance  $K=0.4 \left(\frac{L}{D}\right)$  for 6"(152) - 16"(406) diameters

Flow Resistance  $K=0.3 \left(\frac{L}{D}\right)$  for 18"(457) - 36"(914) diameters

Flow Resistance  $K=0.25 \left(\frac{L}{D}\right)$  for Engine and turbine exhausts,

L = pipe length in feet

I.D. = pipe diameter in inches

**NOTE:** Custom lengths available, contact factory.

FCS-2 O.D. = FCS O.D. + 2

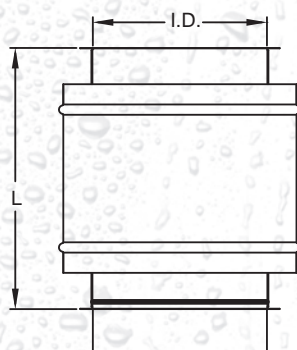

### STRAIGHT LENGTH 6" THRU 24"

PIPE LENGTHS	INSTALLED LENGTH (L)
<b>9.00"</b> (229)	<b>8.13"</b> (207)
<b>12.00"</b> (305)	<b>11.13"</b> (283)
<b>18.00"</b> (457)	<b>17.13"</b> (435)
<b>24.00"</b> (610)	<b>23.13"</b> (588)
<b>36.00"</b> (914)	<b>35.13"</b> (893)

### PIPE I.D.      PIPE O.D.

FCSSW	FCS, FCS-1
6" (152)	8" (203)
7" (178)	9" (229)
8" (203)	10" (254)
9" (229)	11" (279)
10" (254)	12" (305)
12" (305)	14" (356)
14" (356)	16" (406)
16" (407)	18" (457)
18" (457)	20" (508)
20" (508)	22" (559)
22" (559)	24" (610)
24" (610)	26" (660)
26" (661)	28" (711)
28" (711)	30" (762)
30" (762)	32" (813)
32" (813)	34" (864)
34" (864)	36" (914)
36" (914)	38" (965)

### STRAIGHT LENGTH 26" THRU 36"

PIPE LENGTHS	INSTALLED LENGTH (L)
<b>9.00"</b> (229)	<b>7.88"</b> (200)
<b>12.00"</b> (305)	<b>10.88"</b> (276)
<b>18.00"</b> (457)	<b>16.88"</b> (429)
<b>24.00"</b> (610)	<b>22.88"</b> (581)
<b>36.00"</b> (914)	<b>34.88"</b> (886)

## VARIABLE LENGTH (VL22)

6" – 24" Diameters

Flow Resistance  $K = .4\left(\frac{L}{D}\right)$

L = pipe length in feet

I.D. = flue diameter

Used to fill gaps between standard length components. Does not allow for thermal expansion.

**INSTALLED LENGTH (L)**

**VL22**

Minimum: 9" (229)

Maximum: 22" (559)

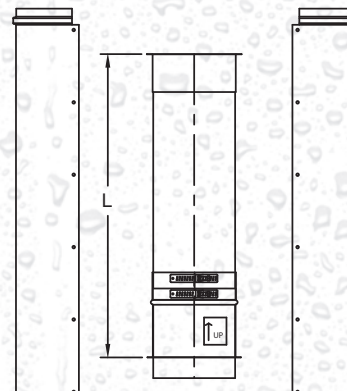

## VARIABLE LENGTH (VL10/VL22)

### 26" – 36" Diameters

Flow Resistance  $K = .4 \left(\frac{L}{D}\right)$

L = pipe length in feet

I.D. = flue diameter

Used to fill gaps between standard length components. Does not allow for thermal expansion.

### INSTALLED LENGTH (L)

	VL10	VL22
Minimum:	7" (178)	7" (178)
Maximum:	10" (254)	22" (559)

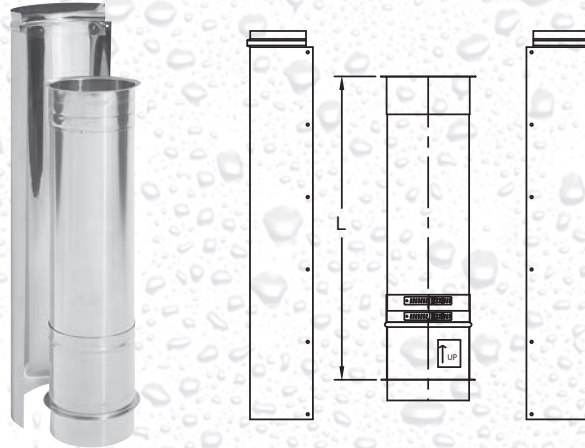

## TAPERED INCREASER (TI)

### 3" Diameter

Used to transition from CG to FCS.

A		B	
3.00"	(76)	6.00"	(152)

Dimensions in inches (mm).

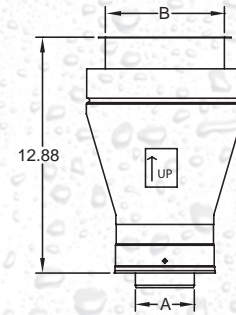

## ECCENTRIC TAPERED INCREASER (EI)

### 4" – 5" Diameters

Used to transition from CG to FCS.

A		B		C	
4.00"	(102)	6.00"	(152)	1.00"	(25)
5.00"	(127)	6.00"	(152)	0.50"	(13)
5.00"	(127)	8.00"	(204)	1.50"	(38)

Dimensions in inches (mm).

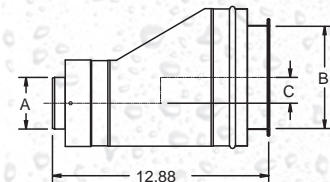

## TAPERED INCREASER (TI)

Flow Resistance  $K = .51 \frac{[1 - (\frac{A}{C})^2]^2}{(\frac{A}{C})^4}$

A = Inlet Diameter

B = Outlet Diameter

C = Installed Length – See Table

**NOTE:** ½ Step = 1" increase in diameter;  
1 Step = 2" increase in diameter

Steps	½ - 3	3 ½ - 6
"C" Length	15" (381)	20" (508)

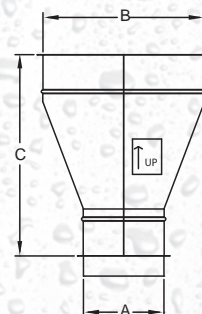

When ordering, specify inlet and outlet diameters with inlet diameter first.

**Example:** 12FCSTI14

# FCS/FCSSW COMPONENTS 6" – 36" DIAMETERS

## ECCENTRIC TAPERED INCREASER (EI)

$$\text{Flow Resistance } K = .51 \frac{[1 - (\frac{A}{C})]^2}{(\frac{A}{C})^4}$$

A = Inlet Diameter

B = Outlet diameter

C = Installed Length – See Table

**NOTE:** ½ Step = 1" increase in diameter;  
1 Step = 2" increase in diameter

Steps	½ - 2	2 ½ - 4	4.5 - 6
"C" Length	15" (381)	21" (534)	28" (712)

When ordering, specify inlet and outlet diameters with inlet diameter first.

**Example:** 12FCSE14

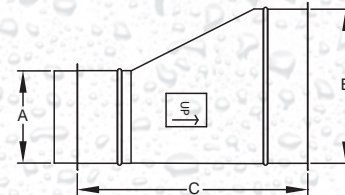

## TAPERED REDUCER (R)

6" – 24" Diameters

$$\text{Flow Resistance } K = .16 \frac{[1 - (\frac{A}{C})]^2}{(\frac{A}{C})^4}$$

A = Inlet Diameter

B = Outlet Diameter

C = Installed Length – See Table

**NOTE:** ½ Step = 1" decrease in diameter;  
1 Step = 2" decrease in diameter

Steps	6 - 3 ½	3 - ½
"C" Length	20" (508)	15" (381)

When ordering, specify inlet and outlet diameters with inlet diameter first.

**Example:** 14FCR12

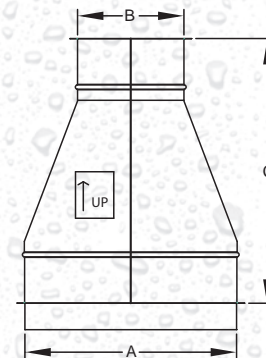

## ECCENTRIC REDUCER (ER)

6" – 24" Diameters

$$\text{Flow Resistance } K = .16 \frac{[1 - (\frac{A}{C})]^2}{(\frac{A}{C})^4}$$

A = Inlet Diameter

B = Outlet diameter

C = Installed Length – See Table

**NOTE:** ½ Step = 1" decrease in diameter;  
1 Step = 2" decrease in diameter

Steps	6 - 4 ½	4 - 2 ½	2 - ½
"C" Length	28" (712)	21" (534)	15" (381)

When ordering, specify inlet and outlet diameters with inlet diameter first.

**Example:** 14FCSER12

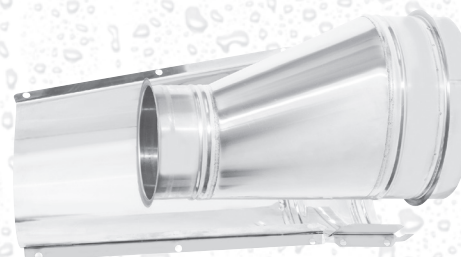
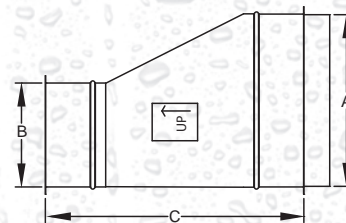

# FCS/FCSSW COMPONENTS 6" – 36" DIAMETERS

## 15° ELBOW (15L)

Flow Resistance K = 0.06

Offset Distance:

$$O = 2 \times "A" \times 0.259$$

Offset distance with pipe length between elbows:

$$O = (2 \times "A" + \text{pipe length}) \times 0.259$$

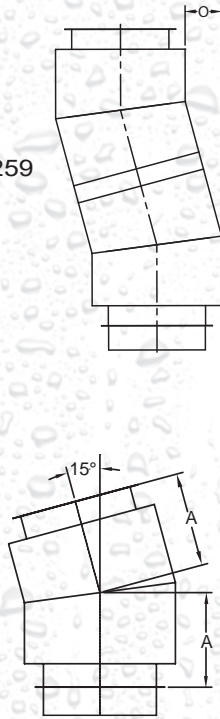

## 30° ELBOW (30L)

Flow Resistance K = 0.12

Offset Distance:

$$O = 2 \times "A" \times 0.5$$

Offset distance with pipe length between elbows:

$$O = (2 \times "A" + \text{pipe length}) \times 0.5$$

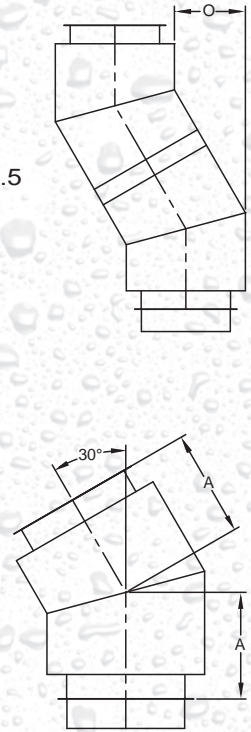

PIPE I.D.	A				
	FCSSW / FCS / FCS-1		FCS-2		
6"	(152)	4.56"	(116)	4.68"	(119)
7"	(178)	4.63"	(118)	4.75"	(121)
8"	(204)	4.68"	(119)	4.82"	(122)
9"	(229)	4.75"	(121)	4.88"	(124)
10"	(254)	4.88"	(124)	5.00"	(127)
12"	(305)	5.00"	(127)	5.13"	(130)
14"	(356)	5.13"	(130)	5.25"	(133)
16"	(406)	5.25"	(133)	5.38"	(137)
18"	(457)	5.38"	(137)	5.50"	(140)
20"	(508)	5.50"	(140)	5.63"	(143)
22"	(559)	5.63"	(143)	5.75"	(146)
24"	(610)	5.75"	(146)	5.88"	(149)
26"	(660)	8.50"	(216)	8.50"	(216)
28"	(711)	8.50"	(216)	8.50"	(216)
30"	(762)	8.50"	(216)	8.50"	(216)
32"	(813)	8.50"	(216)	8.50"	(216)
34"	(864)	8.50"	(216)	8.50"	(216)
36"	(914)	8.50"	(216)	11.00"	(279)

Dimensions in inches (mm).

PIPE I.D.	A				
	FCSSW / FCS / FCS-1		FCS-2		
6"	(152)	5.00"	(127)	5.25"	(133)
7"	(178)	5.13"	(130)	5.38"	(137)
8"	(204)	5.25"	(133)	5.50"	(140)
9"	(229)	5.38"	(137)	5.63"	(143)
10"	(254)	5.50"	(140)	5.75"	(146)
12"	(305)	5.75"	(146)	6.06"	(154)
14"	(356)	6.06"	(154)	6.31"	(160)
16"	(406)	6.38"	(162)	6.63"	(168)
18"	(457)	6.63"	(168)	6.88"	(175)
20"	(508)	6.88"	(175)	7.13"	(181)
22"	(559)	7.13"	(181)	7.38"	(187)
24"	(610)	7.38"	(187)	7.63"	(194)
26"	(660)	8.50"	(216)	8.50"	(216)
28"	(711)	8.50"	(216)	8.50"	(216)
30"	(762)	8.50"	(216)	8.50"	(216)
32"	(813)	8.50"	(216)	8.50"	(216)
34"	(864)	8.50"	(216)	8.50"	(216)
36"	(914)	8.50"	(216)	11.00"	(279)

Dimensions in inches (mm).

# FCS/FCSSW COMPONENTS 6" – 36" DIAMETERS

## 45° ELBOW (45L)

Flow Resistance K = 0.15

Offset Distance:

$$O = 2 \times "A" \times 0.707$$

Offset Distance with pipe length between elbows:

$$O = (2 \times "A" + \text{pipe length}) \times 0.707$$

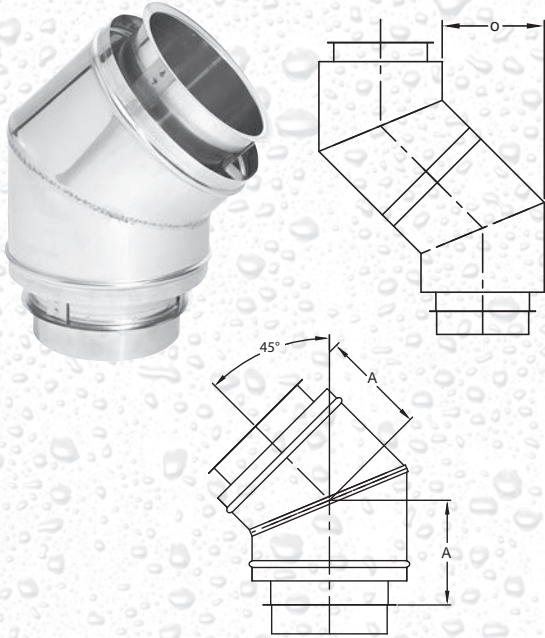

## 90° ELBOW (90L)

Flow Resistance K:

$$6" - 8" = 0.38$$

$$9" - 18" = 0.42$$

$$20" - 26" = 0.54$$

$$28" - 36" = 0.72$$

Offset Distance:

$$O = 2 \times "A"$$

Offset Distance with pipe length between elbows:

$$O = 2 \times "A" + \text{pipe length}$$

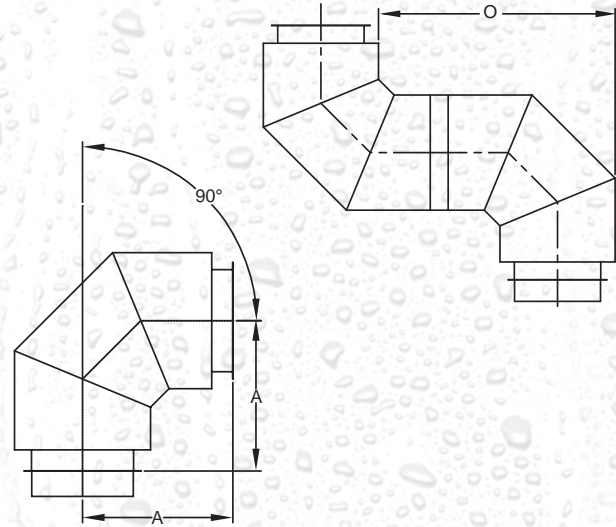

PIPE I.D.		A			
		FCSSW / FCS / FCS-1		FCS-2	
6"	(152)	5.44"	(138)	5.88"	(149)
7"	(178)	5.63"	(143)	6.06"	(154)
8"	(204)	5.88"	(149)	6.25"	(159)
9"	(229)	6.06"	(154)	6.50"	(165)
10"	(254)	6.25"	(159)	6.68"	(170)
12"	(305)	6.75"	(172)	7.06"	(179)
14"	(356)	7.13"	(181)	7.50"	(191)
16"	(406)	7.51"	(191)	7.94"	(202)
18"	(457)	7.94"	(202)	8.32"	(211)
20"	(508)	8.32"	(211)	8.75"	(222)
22"	(559)	8.75"	(223)	9.18"	(233)
24"	(610)	9.25"	(235)	9.56"	(243)
26"	(660)	11.75"	(299)	11.75"	(299)
28"	(711)	11.75"	(299)	11.75"	(299)
30"	(762)	11.75"	(299)	11.75"	(299)
32"	(813)	11.75"	(299)	11.75"	(299)
34"	(864)	11.75"	(299)	11.75"	(299)
36"	(914)	11.75"	(299)	14.00"	(356)

Dimensions in inches (mm).

PIPE I.D.		A			
		FCSSW / FCS / FCS-1		FCS-2	
6"	(152)	8.88"	(226)	9.88"	(251)
7"	(178)	9.38"	(238)	10.38"	(264)
8"	(203)	9.88"	(251)	10.88"	(276)
9"	(229)	10.38"	(264)	11.38"	(289)
10"	(254)	10.88"	(276)	11.88"	(302)
12"	(305)	11.88"	(302)	12.88"	(327)
14"	(356)	12.88"	(327)	13.88"	(353)
16"	(406)	13.88"	(353)	14.88"	(378)
18"	(457)	14.88"	(378)	15.88"	(403)
20"	(508)	15.88"	(403)	16.88"	(429)
22"	(559)	16.88"	(429)	17.88"	(454)
24"	(610)	17.88"	(454)	18.88"	(480)
26"	(660)	21.00"	(533)	22.00"	(559)
28"	(711)	22.00"	(559)	23.00"	(584)
30"	(762)	23.00"	(584)	24.00"	(610)
32"	(813)	24.00"	(610)	25.00"	(635)
34"	(864)	25.00"	(635)	26.00"	(660)
36"	(914)	26.00"	(660)	27.00"	(686)

Dimensions in inches (mm).

# FCS/FCSSW COMPONENTS 6" – 36" DIAMETERS

## BOOT TEE (BT)

6" – 24" Diameters

Flow Resistance  $K = 0.65$

A = Pipe I.D.

B = "C" I.D. + 12"

C = Tap I.D.

D = 7" (FCSSW/FCS/FCS-1), 8" (FCS-2)

E = 5" (FCSSW/FCS/FCS-1), 6" (FCS-2)

**NOTES:**

1. Specify tap diameter (C) at time of order.
2. Tap can be reduced by 1-4 steps as standard.

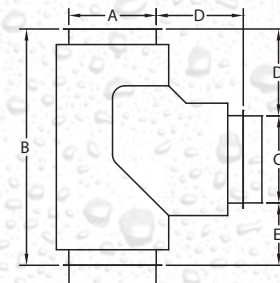

## BOOT TEE W/ DRAIN (BTD)

6" – 24" Diameters

Flow Resistance  $K = 0.65$

A = Pipe I.D.

B = C + D + E

C = Tap I.D.

D = 7" (FCSSW/FCS/FCS-1), 8" (FCS-2)

E = 2.38" (FCSSW/FCS/FCS-1), 4.38" (FCS-2)

**NOTES:**

1. Specify tap diameter (C) at time of order.
2. Tap can be reduced by 1-4 steps as standard.

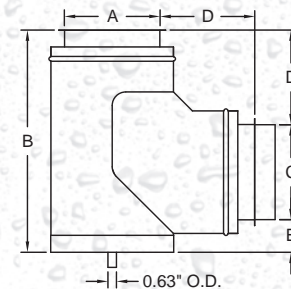

## 90° TEE (T)

Flow Resistance  $K = 1.25$

A = Pipe I.D.

B = "C" I.D. + 10"

C = Tap I.D.

D = 5" (FCSSW/FCS/FCS-1), 6" (FCS-2)

**NOTES:**

1. Specify tap diameter (C) at time of order.
2. Tap can be reduced by 1-4 steps as standard.

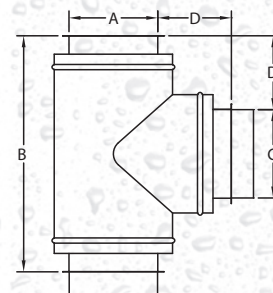

## 45° TEE (45T)

Flow Resistance  $K = 0.4$

Used for low resistance flow into vertical or horizontal run.

**NOTES:**

1. Specify tap diameter (B) at time of order.
2. Tap can be reduced by 1-4 steps as standard.
3. For dimensional information see tables on page 24-27.

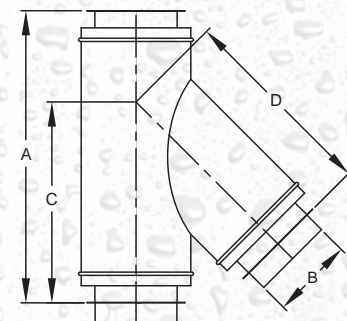

# FCS/FCSSW COMPONENTS 6" – 36" DIAMETERS

## DOUBLE LATERAL (DL)

**26" – 36" Diameters**

Flow Resistance  $K = 0.4$

Used to centrally connect two appliances manifolded into a common chimney.

**NOTES:**

1. Specify tap diameter (B) when ordering; tap diameter must be less than body diameter.
2. Tap can be reduced by 1-4 steps as standard.
3. For dimensional information see tables on page 24-27.

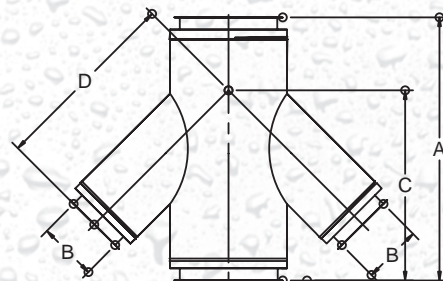

## 90° WYE (90Y)

**26" – 36" Diameters**

Flow Resistance  $K = 0.6$

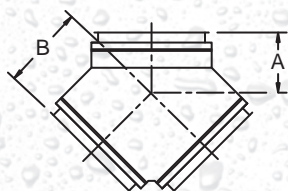

PIPE I.D.	FCSSW / FCS / FCS-1		FCS-2	
	A	B	A	B
26" (660)	9.37" (238)	19.00" (483)	9.81" (249)	20.00" (508)
28" (711)	9.75" (248)	20.00" (508)	10.25" (261)	21.00" (533)
30" (762)	10.25" (261)	21.00" (533)	10.62" (270)	22.00" (559)
32" (813)	10.62" (270)	22.00" (559)	11.00" (279)	23.00" (584)
34" (864)	11.12" (283)	23.00" (584)	11.44" (290)	24.00" (610)
36" (914)	11.50" (292)	24.00" (610)	11.88" (302)	25.00" (635)

## DRAIN SECTION (DS)

**6" – 24" Diameters**

Flow Resistance  $K = 0.25$

Used to drain rain water or condensation from inside the stack.

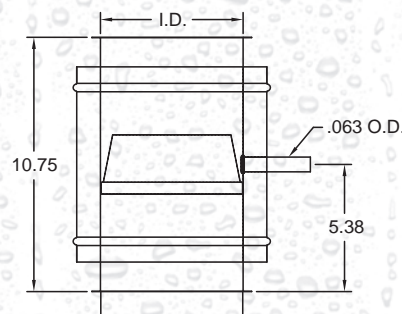

## DRAIN SECTION (DS)

**26" – 36" Diameters**

Flow Resistance  $K = 0.25$

Used to drain rain water or condensation from inside the stack.

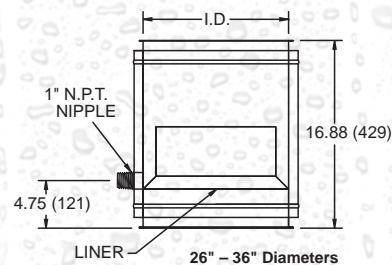

## DRAIN TEE CAP W/CASING END CLOSURE (TC)

**6" – 24" Diameters**

Used as a drain port for rain or condensation.

A = 5.50" (FCSSW/FCS/FCS-1), 6.50" (FCS-2)

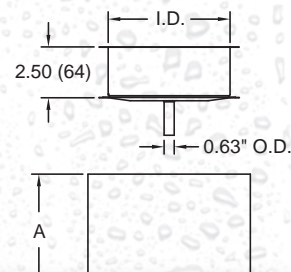

# FCS/FCSSW COMPONENTS 6" – 36" DIAMETERS

## DRAIN TEE CAP W / CASING END CLOSURE (TC)

26" – 36" Diameters

Used as a drain port for rain or condensation.

$$A = \frac{(I.D. - 1.343)}{2} \times .268 + \text{Nipple Length}$$

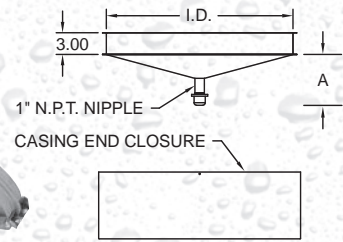

## TEE CAP LESS DRAIN W / CASING END CLOSURE (TCN)

6" – 24" Diameters

Used to close and seal unused port of Tees, Wyes and Laterals.

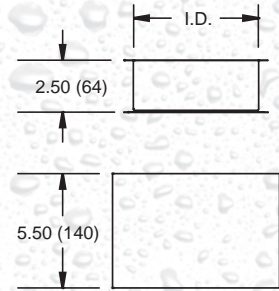

## TEE CAP LESS DRAIN W / CASING END CLOSURE (TCN)

26" – 36" Diameters

Used to close and seal unused port of Tees, Wyes and Laterals.

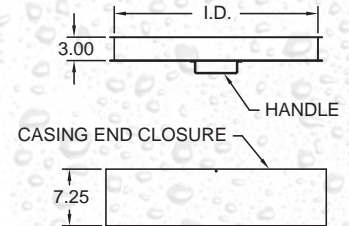

## TALL CONE FLASHING (F)

Used for flat roof applications.

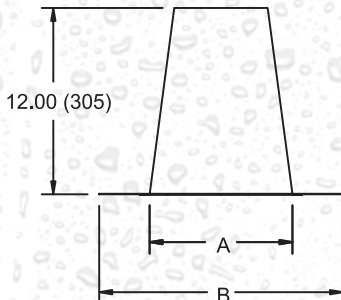
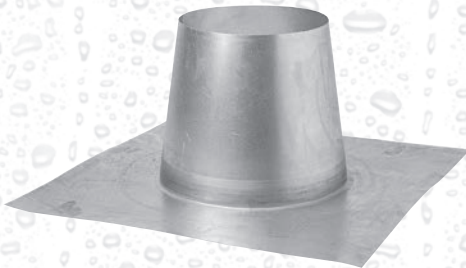

PIPE I.D.	FCSSW/FCS/FCS-1				FCS-2			
	A		B		A		B	
6" (152)	12.00" (305)	24.00" (610)	14.00" (355)	26.00" (660)				
7" (178)	13.00" (330)	25.00" (635)	15.00" (381)	27.00" (686)				
8" (203)	14.00" (356)	26.00" (660)	16.00" (406)	28.00" (711)				
9" (229)	15.00" (381)	27.00" (686)	17.00" (432)	29.00" (737)				
10" (254)	16.00" (407)	28.00" (712)	18.00" (457)	30.00" (762)				
12" (305)	18.00" (458)	30.00" (762)	20.00" (508)	32.00" (813)				
14" (356)	20.00" (508)	32.00" (813)	22.00" (559)	34.00" (864)				
16" (406)	22.00" (559)	34.00" (864)	24.00" (610)	36.00" (914)				
18" (457)	24.00" (610)	36.00" (915)	26.00" (660)	38.00" (965)				
20" (508)	26.00" (660)	38.00" (966)	28.00" (711)	40.00" (1016)				
22" (559)	28.00" (712)	40.00" (1016)	30.00" (762)	42.00" (1067)				
24" (610)	30.00" (762)	42.00" (1067)	32.00" (813)	44.00" (1118)				
26" (660)	32.00" (813)	44.00" (1118)	34.00" (864)	46.00" (1168)				
28" (712)	34.00" (864)	46.00" (1168)	36.00" (914)	48.00" (1219)				
30" (762)	36.00" (914)	48.00" (1219)	38.00" (965)	50.00" (1270)				
32" (813)	38.00" (965)	50.00" (1270)	40.00" (1016)	52.00" (1321)				
34" (864)	40.00" (1016)	52.00" (1321)	42.00" (1067)	54.00" (1372)				
36" (914)	42.00" (1067)	54.00" (1372)	44.00" (1118)	56.00" (1422)				

Dimensions in inches (mm).

# FCS/FCSSW COMPONENTS 6" – 36" DIAMETERS

## FIXED PITCH FLASHING (FPF)

**NOTE:**

X=PITCH RATE, AVAILABLE RATES 1/12-12/12.  
Please specify pitch rate with order.

When ordering, specify pipe diameter followed by pitch rate.

**Example:** 6FCSFPF4

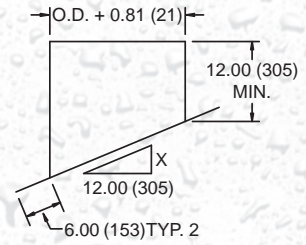
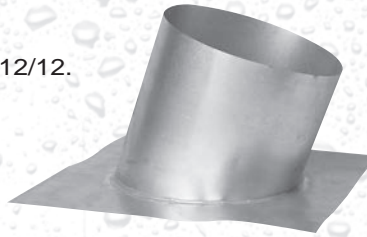

## STORM COLLAR (SC)

A = Pipe Diameter (O.D.)

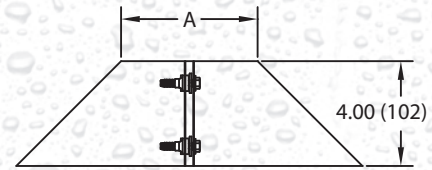

## STACK CAP (C/CB)

Flow resistance K = 0.5

Provides partial rain protection. Use of Drain Tee Cap (TC) or Drain Section (DS) is recommended.

**NOTES:** Also available with bird screen order as (CB).  
26"-36" diameters are custom; please contact factory.

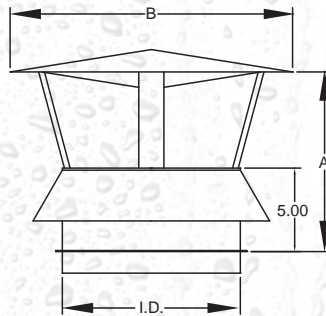
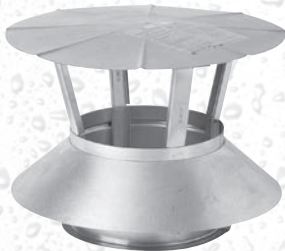

PIPE I.D.	A	B
6" (152)	9.50" (241)	11.00" (280)
7" (178)	10.50" (267)	12.50" (318)
8" (203)	11.50" (292)	14.00" (356)
9" (229)	12.75" (324)	15.50" (394)
10" (254)	13.50" (343)	17.00" (432)
12" (305)	14.50" (368)	21.00" (533)
14" (356)	15.50" (394)	24.00" (610)
16" (407)	17.50" (445)	28.00" (712)
18" (458)	18.50" (470)	31.00" (787)
20" (508)	20.50" (521)	34.00" (864)
22" (559)	21.50" (546)	38.00" (965)
24" (610)	23.50" (597)	41.00" (1041)
26" (660)	25.50" (648)	44.00" (1118)
28" (712)	27.50" (699)	48.00" (1219)
30" (762)	29.50" (749)	51.00" (1295)
32" (813)	31.50" (800)	54.00" (1372)
34" (864)	33.50" (851)	58.00" (1473)
36" (914)	35.50" (902)	61.00" (1549)

Dimensions in inches (mm).

# FCS/FCSSW COMPONENTS 6" – 36" DIAMETERS

## CLOSURE RING (CR)

A = Pipe Diameter (I.D.)

Used to attach to flue and shield annular space from the weather when open stack is desired.

**NOTE:** Provide a Tee Cap (TC) or Drain Section (DS) for moisture removal.

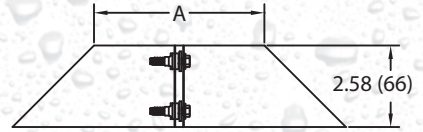
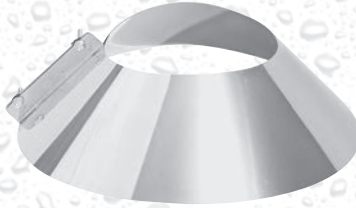

## MITER CUT MALE (MCM)

Used for horizontal termination sloping toward the appliance. Standard with bird screen.

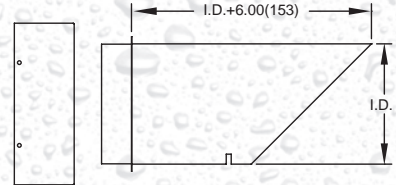

CASING END CLOSURE

## MITER CUT FEMALE (MCF)

Used for horizontal termination sloping away from the appliance. Standard with bird screen.

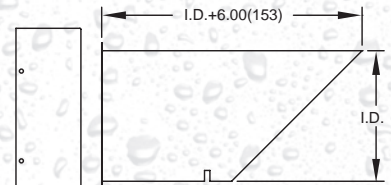

CASING END CLOSURE

## EXIT CONE (EC)

6" – 24" Diameters

Flow resistance  $K = 1.25$

Used to increase velocity of exiting flue gases. Provide for moisture removal with Tee Cap or Drain Section.



PIPE I.D.	A	PIPE I.D.	A
6" (152)	4.50" (114)	14" (356)	12.50" (318)
7" (178)	5.50" (140)	16" (407)	14.50" (368)
8" (203)	6.50" (165)	18" (458)	16.50" (419)
9" (229)	7.50" (191)	20" (508)	18.50" (470)
10" (254)	8.50" (216)	22" (559)	20.50" (521)
12" (305)	10.50" (267)	24" (610)	22.50" (572)

Dimensions in inches (mm).

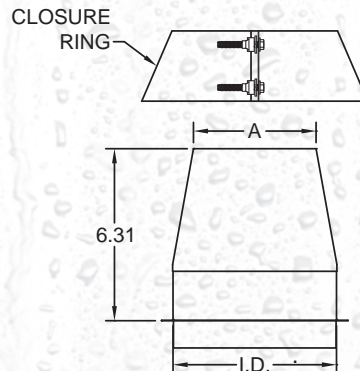

## WALL PENETRATOR KIT (WPK)

Used for horizontal wall penetrations, designed for non-fire rated walls. (Zinc Plated)



Framing dimension I.D. + 6"

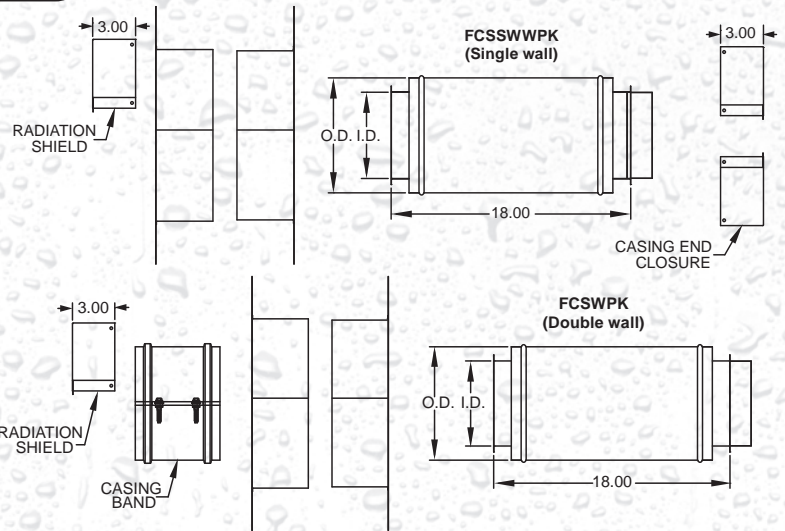

## PLATE SUPPORT (PS)

6" – 36" Diameters

Provides vertical or horizontal anchored support. Includes split plates, clamp flanges, and 1/2 closure bands. (Zinc Plated)

Do not exceed "X" between supports.

6" – 36" FCSSW	X = 100'
6" – 36" FCS	X = 100'
6" – 36" FCS-1	X = 85'
6" – 36" FCS-2	X = 75'

**NOTE:** Does not allow for thermal expansion.

### FCSSW/FCS/FCS-1:

- A = I.D. + 7" (6"-12" dia.)
- A = I.D. + 9" (14"-24" dia.)

### FCS-2:

- A = I.D. + 9" (6"-12" dia.)
- A = I.D. + 11" (14"-24" dia.)

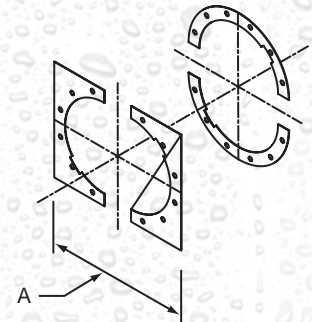
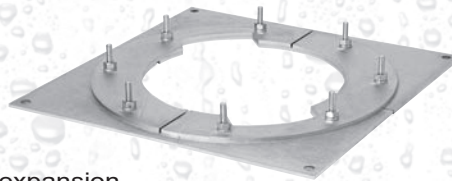

# FCS/FCSSW COMPONENTS 6" – 36" DIAMETERS

## FIRESTOP (FS)

PIPE I.D.		FCSSW		FCS / FCS-1		FCS-2	
		A/B		A/B		A/B	
6"	(152)	16.00"	(407)	18.00"	(458)	20.00"	(508)
7"	(178)	17.00"	(432)	19.00"	(483)	21.00"	(533)
8"	(203)	18.00"	(458)	20.00"	(508)	22.00"	(558)
9"	(229)	19.00"	(483)	21.00"	(533)	23.00"	(584)
10"	(254)	20.00"	(508)	22.00"	(559)	24.00"	(609)
12"	(305)	22.00"	(559)	24.00"	(610)	26.00"	(660)
14"	(356)	24.00"	(610)	26.00"	(660)	28.00"	(711)
16"	(406)	26.00"	(660)	28.00"	(712)	30.00"	(762)
18"	(457)	28.00"	(712)	30.00"	(762)	32.00"	(812)
20"	(508)	30.00"	(762)	32.00"	(813)	34.00"	(863)
22"	(559)	32.00"	(813)	34.00"	(864)	36.00"	(914)
24"	(610)	34.00"	(864)	36.00"	(914)	38.00"	(965)
26"	(660)	36.00"	(914)	38.00"	(965)	40.00"	(1016)
28"	(711)	38.00"	(966)	40.00"	(1016)	42.00"	(1066)
30"	(762)	40.00"	(1016)	42.00"	(1067)	44.00"	(1117)
32"	(813)	42.00"	(1067)	44.00"	(1118)	46.00"	(1168)
34"	(864)	44.00"	(1118)	46.00"	(1168)	48.00"	(1219)
36"	(914)	46.00"	(1168)	48.00"	(1219)	50.00"	(1270)

Dimensions in inches (mm).

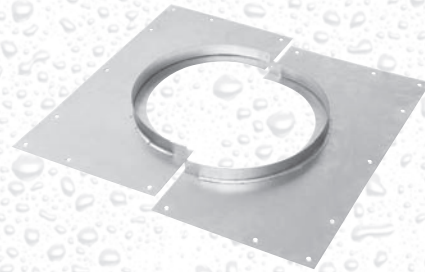
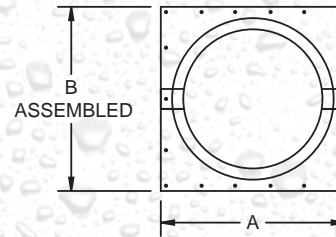

## WALL BAND (WB)

### 6" – 16" Diameters

For interior use only. Do not exceed 8' 0" between supports.

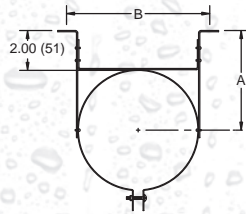

PIPE I.D.		FCSSW		FCS / FCS-1		FCS-2							
		A		B		A		B		A		B	
6"	(152)	5.00"	(127)	7.07"	(180)	6.00"	(152)	9.07"	(230)	7.00"	(178)	11.07"	(281)
7"	(178)	5.50"	(140)	8.07"	(205)	6.50"	(165)	10.07"	(256)	7.50"	(191)	12.07"	(307)
8"	(204)	6.00"	(152)	9.07"	(230)	7.00"	(178)	11.07"	(281)	8.00"	(203)	13.07"	(332)
9"	(229)	6.50"	(165)	10.07"	(256)	7.50"	(191)	12.07"	(307)	8.50"	(216)	14.07"	(357)
10"	(254)	7.00"	(178)	11.07"	(281)	8.00"	(204)	13.07"	(332)	9.00"	(229)	15.07"	(383)
12"	(305)	8.00"	(203)	13.07"	(332)	9.00"	(229)	15.07"	(383)	10.00"	(254)	17.07"	(434)
14"	(356)	N/A		N/A		10.00"	(254)	17.07"	(434)	11.00"	(279)	19.07"	(484)
16"	(406)	N/A		N/A		11.00"	(279)	19.07"	(484)	N/A		N/A	

Dimensions in inches (mm).

# FCS/FCSSW COMPONENTS 6" – 36" DIAMETERS

## WALL SUPPORT (WS)

### 6" – 24" Diameters

Used to secure the vent to interior and exterior walls, maintaining clearance and providing alignment.

Do not exceed 30 ft. distance between supports on interior walls. Do not exceed 8 ft. between supports on exterior walls.

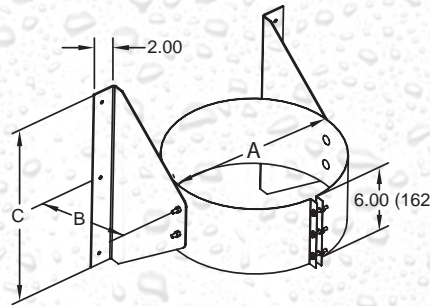

PIPE I.D.	FCSSW			FCS / FCS-1			FCS-2		
	A	B	C	A/C	B	A/C	B		
6"	6.00" (152)	5.00" (127)	8.00" (203)	8.00" (203)	5.00" (127)	10.00" (254)	6.00" (152)		
7"	7.00" (178)	5.50" (140)	9.00" (229)	9.00" (229)	5.50" (178)	11.00" (279)	6.50" (165)		
8"	8.00" (203)	6.00" (152)	10.00" (254)	10.00" (254)	6.00" (152)	12.00" (305)	7.00" (178)		
9"	9.00" (229)	6.50" (165)	11.00" (279)	11.00" (279)	6.50" (165)	13.00" (330)	7.50" (191)		
10"	10.00" (254)	7.00" (178)	12.00" (305)	12.00" (305)	7.00" (178)	14.00" (356)	8.00" (203)		
12"	12.00" (305)	8.00" (203)	14.00" (356)	14.00" (356)	8.00" (203)	16.00" (406)	13.00" (330)		
14"	14.00" (356)	13.00" (330)	16.00" (406)	16.00" (406)	13.00" (330)	18.00" (457)	14.00" (356)		
16"	16.00" (406)	14.00" (356)	18.00" (457)	18.00" (457)	14.00" (356)	20.00" (508)	15.00" (381)		
18"	18.00" (457)	15.00" (381)	20.00" (508)	20.00" (508)	15.00" (381)	22.00" (559)	16.00" (406)		
20"	20.00" (508)	16.00" (406)	22.00" (559)	22.00" (559)	16.00" (406)	24.00" (610)	17.00" (432)		
22"	22.00" (559)	17.00" (432)	24.00" (610)	24.00" (610)	17.00" (432)	26.00" (660)	18.00" (457)		
24"	24.00" (610)	18.00" (457)	26.00" (660)	26.00" (660)	18.00" (457)	28.00" (711)	19.00" (483)		

Dimensions in inches (mm).

## WALL SUPPORT (WS)

### 26" – 36" Diameters

Used to provide vertical support. (Zinc Plated)

- NOTES:**
1. Does not allow for thermal expansion.
  2. Do not exceed 40' between supports on interior walls.
  3. Do not exceed 10' between supports on exterior walls.

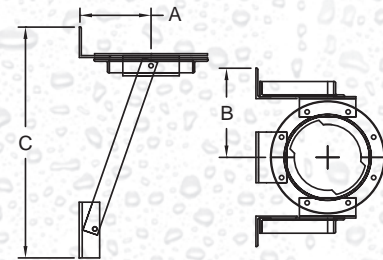

PIPE I.D.	FCSSW / FCS / FCS-1			FCS-2		
	A	B	C	A	B	C
26" (660)	18.62" (473)	18.00" (457)	38.75" (984)	19.62" (498)	19.00" (483)	38.25" (972)
28" (711)	19.62" (498)	19.00" (483)	38.25" (972)	20.62" (524)	20.00" (508)	37.75" (959)
30" (762)	20.62" (524)	20.00" (508)	37.75" (959)	21.62" (549)	21.00" (533)	45.25" (1149)
32" (813)	21.62" (549)	21.00" (533)	45.25" (1149)	23.12" (587)	22.50" (572)	44.75" (1137)
34" (864)	23.12" (587)	22.50" (572)	44.75" (1137)	24.12" (613)	23.50" (597)	44.00" (1118)
36" (914)	24.12" (613)	23.50" (597)	44.00" (1118)	25.12" (638)	24.50" (622)	53.75" (1365)

# FCS/FCSSW COMPONENTS 6" – 36" DIAMETERS

## GUY RING (GR)

6" – 24" Diameters

FCSSW A = Flue Diameter

FCS/FCS-1 A = Flue Diameter + 2"

FCS-2 A = Flue Diameter + 4"

**NOTE:** Guy Ring clamps around outside of pipe.

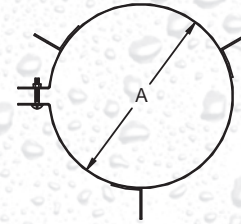

## GUY RING (GR)

26" – 36" Diameters

Guy Ring clamps around flue flange band.

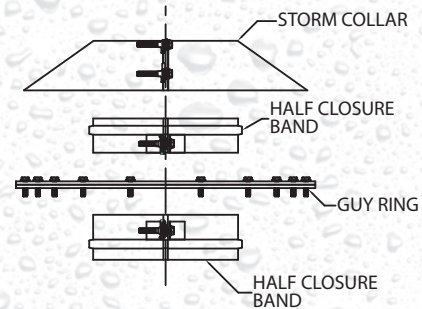
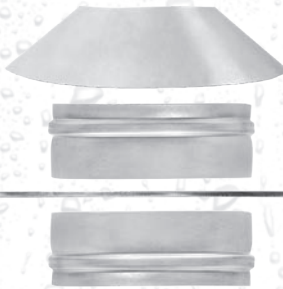

## HALF ANGLE RING (HAR)

6" – 24" Diameters

Maximum distance between supports or elbows = 7' 0"



## HALF ANGLE RING (HAR)

26" – 36" Diameters

Used to support horizontal runs. (Zinc Plated)

**NOTE:** Maximum distance between supports or elbows = 10' 6"

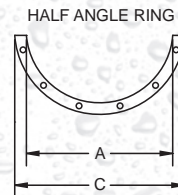

## FULL ANGLE RING (FAR)

26" – 36" Diameters

Used to provides lateral support for vertical runs. Allows pipe movement for thermal expansion. (Zinc Plated)

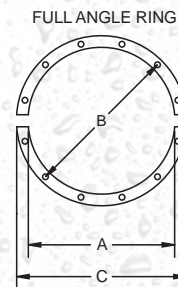

PRODUCT			DIMENSIONS			
PIPE I.D.			Inside	Hole Centerline	Outside	Hole Qty.
FCSSW	FCS/FCS-1	FCS-2	A	B	C	D
26" (660)	-	-	26.25" (667)	28.50" (724)	30.25" (769)	24
28" (711)	26" (660)	-	28.25" (718)	30.50" (775)	32.25" (820)	24
30" (762)	28" (712)	26" (660)	30.25" (768)	32.50" (826)	34.25" (870)	28
32" (813)	30" (762)	28" (712)	32.25" (819)	34.50" (876)	36.25" (921)	28
34" (864)	32" (813)	30" (762)	34.25" (870)	36.50" (927)	38.25" (972)	32
36" (914)	34" (864)	32" (813)	36.25" (921)	38.50" (978)	40.25" (1022)	32
-	36" (914)	34" (864)	38.25" (972)	40.50" (1029)	42.25" (1073)	36
-	-	36" (914)	40.25" (1022)	42.50" (1080)	44.25" (1124)	36

# FCS/FCSSW COMPONENTS 6" – 36" DIAMETERS

## LIFTING RING (LR)

Used to support and lower vent assembly into existing chimney.

**NOTE:** Available in single wall only.

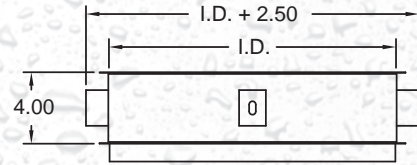

## STACK SUPPORT ASSEMBLY (SSA)

Used to supports vertical stack at floor level. Includes moisture drain.

Maximum Supported Height: 100'

FCSSW / FCS / FCS-1	FCS-2
A = PIPE I.D.	A = PIPE I.D.
B = 9" (229)	B = 9" (229)
C = 5.5" (140)	C = 5.5" (140)
D = A+7" (178)	D = A+9" (229)
E = A+6" (152)	E = A+8" (203)

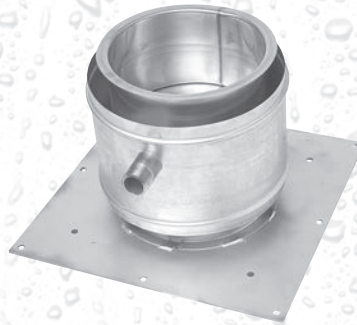

.63" DIA. TUBING 6"-24" DIA.  
1" NPT NIPPLE 26"-36" DIA.

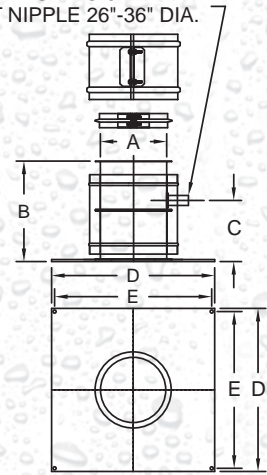

# FCS/FCSSW COMPONENTS 6" – 36" DIAMETERS

## JOINT ASSEMBLY

1. Apply continuous bead of sealant ¼" wide at corner of flange and sleeve.
2. Join to next section.
3. Fill the flange vee band with sealant and install around flanges.
4. Gently tap vee band with a soft head mallet while tightening band to assure tight seal.
5. Install casing closure band. (Seal if external to structure to prevent moisture infiltration)

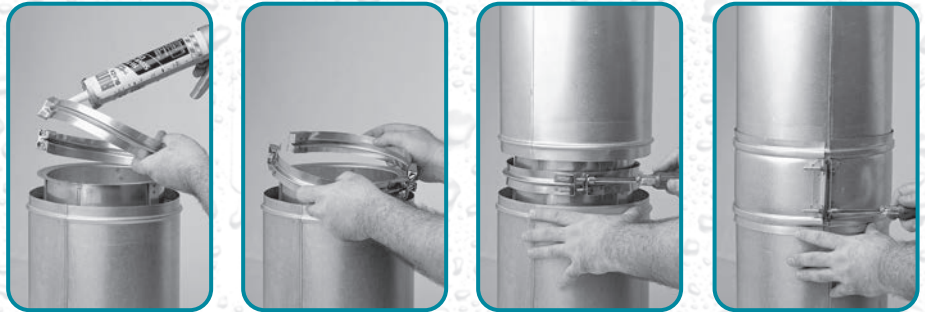

## SEALANT REQUIREMENTS

P077 Sealant

Flue Diameter	Tubes / Joint	Joints / Tube
6"	0.20	5
8"	0.20	5
10"	0.20	5
12"	0.25	4
14"	0.25	4
16"	0.25	4
18"	0.33	3
20"	0.33	3
22"	0.33	3
24"	0.50	2
26"	0.50	2
28"	0.50	2
30"	0.67	1-1/2
32"	0.67	1-1/2
34"	0.67	1-1/2
36"	0.67	1-1/2

## WARRANTY

### LIMITED LIFETIME WARRANTY

The Metal-Fab, Inc. 6 thru 36-inch diameter Model FCS "Corr/Guard Double Wall" and FCSSW "Corr/Guard Single-Wall" factory-built gas vent system (the products), when installed in accordance to manufacturer's instructions and when properly and regularly cleaned and maintained, are warranted by Metal-Fab, Inc. under normal use against defects in material or workmanship for as long as the original purchaser owns the vent system.

Refer to Metal-Fab Warranty form L2619 for complete information and claim procedures, exclusions and limitations. The entire warranty is available at: [www.metal-fabcommercial.com](http://www.metal-fabcommercial.com)

# FCS/FCSSW COMPONENTS 6" – 36" DIAMETERS

## CORR/GUARD® 45MT & DL TABLE IN INCHES 6" – 36" Diameters

		IAP I.D.												
		36	34	32	30	28	26	24	22	20	18	16	14	12
36FCS	"A"	63.74	60.91	58.08	55.26	52.43	49.60	46.77	43.94	41.11	38.28	37.46	36.63	34.80
	"B"	36	34	32	30	28	26	24	22	20	18	16	14	12
	"C"	50.87	49.46	48.04	46.63	45.21	43.80	42.39	40.97	39.56	38.14	36.73	35.31	33.90
	"D"	50.87	49.87	48.87	47.87	46.87	45.87	44.87	43.87	42.87	41.87	40.87	39.87	38.87
34FCS	"A"	60.91	58.08	55.26	52.43	49.60	46.77	43.94	41.11	38.28	36.46	35.63	33.80	31.97
	"B"	34	32	30	28	26	24	22	20	18	16	14	12	10
	"C"	48.46	47.04	45.63	44.21	42.80	41.39	39.97	38.56	37.14	35.73	34.31	32.90	31.49
	"D"	48.46	47.46	46.46	45.46	44.46	43.46	42.46	41.46	40.46	39.46	38.46	37.46	36.46
32FCS	"A"	58.08	55.26	52.43	49.60	46.77	43.94	41.11	38.28	35.46	34.63	32.80	30.97	29.14
	"B"	32	30	28	26	24	22	20	18	16	14	12	10	8
	"C"	46.04	44.63	43.21	41.80	40.39	38.97	37.56	36.14	34.73	33.31	31.90	30.49	29.78
	"D"	46.04	45.04	44.04	43.04	42.04	41.04	40.04	39.04	38.04	37.04	36.04	35.04	34.04
30FCS	"A"	55.26	52.43	49.60	46.77	43.94	41.11	38.28	35.46	32.63	31.80	29.97	28.14	27.31
	"B"	30	28	26	24	22	20	18	16	14	12	10	8	6
	"C"	43.63	42.21	40.80	39.39	37.97	36.56	35.14	33.73	32.31	30.90	29.49	28.78	28.07
	"D"	43.63	42.63	41.63	40.63	39.63	38.63	37.63	36.63	35.63	34.63	33.63	32.63	31.63
28FCS	"A"	52.43	49.60	46.77	43.94	41.11	38.28	35.46	32.63	30.80	29.97	27.14	26.31	25.48
	"B"	28	26	24	22	20	18	16	14	12	10	8	6	4
	"C"	41.21	39.80	38.39	36.97	35.56	34.14	32.73	31.31	29.90	28.49	27.78	27.07	26.36
	"D"	41.21	40.21	39.21	38.21	37.21	36.21	35.21	34.21	33.21	32.21	31.21	30.21	29.21
26FCS	"A"	49.60	46.77	43.94	41.11	38.28	35.46	32.63	29.80	27.97	26.14	25.31	24.48	23.65
	"B"	26	24	22	20	18	16	14	12	10	8	6	4	2
	"C"	38.80	37.39	35.97	34.56	33.14	31.73	30.31	28.90	27.49	26.78	26.07	25.36	24.65
	"D"	38.80	37.80	36.80	35.80	34.80	33.80	32.80	31.80	30.80	29.80	28.80	27.80	26.80
24FCS	"A"	46.77	43.94	41.11	38.28	35.46	32.63	29.80	26.97	25.14	24.31	23.48	22.65	21.82
	"B"	24	22	20	18	16	14	12	10	8	6	4	2	0
	"C"	36.39	34.97	33.56	32.14	30.73	29.31	27.90	26.49	25.78	25.07	24.36	23.65	22.94
	"D"	36.39	35.39	34.39	33.39	32.39	31.39	30.39	29.39	28.39	27.39	26.39	25.39	24.39
22FCS	"A"	43.94	41.11	38.28	35.46	32.63	29.80	26.97	24.14	23.31	22.48	21.65	20.82	20.00
	"B"	22	20	18	16	14	12	10	8	6	4	2	0	-2
	"C"	33.97	32.56	31.14	29.73	28.31	26.90	25.49	24.78	24.07	23.36	22.65	21.94	21.23
	"D"	33.97	32.97	31.97	30.97	29.97	28.97	27.97	26.97	25.97	24.97	23.97	22.97	21.97
20FCS	"A"	41.11	38.28	35.46	32.63	29.80	26.97	24.14	22.31	21.48	20.65	19.82	19.00	18.18
	"B"	20	18	16	14	12	10	8	6	4	2	0	-2	-4
	"C"	31.56	30.14	28.73	27.31	25.90	24.49	23.78	23.07	22.36	21.65	20.94	20.23	19.52
	"D"	31.56	30.56	29.56	28.56	27.56	26.56	25.56	24.56	23.56	22.56	21.56	20.56	19.56
18FCS	"A"	38.28	35.46	32.63	29.80	26.97	24.14	21.31	19.48	18.65	17.82	17.00	16.18	15.36
	"B"	18	16	14	12	10	8	6	4	2	0	-2	-4	-6
	"C"	29.14	27.73	26.31	24.90	23.49	22.78	22.07	21.36	20.65	19.94	19.23	18.52	17.81
	"D"	29.14	28.14	27.14	26.14	25.14	24.14	23.14	22.14	21.14	20.14	19.14	18.14	17.14
16FCS	"A"	35.46	32.63	29.80	26.97	25.14	24.31	23.48	22.65	21.82	21.00	20.18	19.36	18.54
	"B"	16	14	12	10	8	6	4	2	0	-2	-4	-6	-8
	"C"	26.73	25.31	23.90	22.49	21.78	21.07	20.36	19.65	18.94	18.23	17.52	16.81	16.10
	"D"	26.73	25.73	24.73	23.73	22.73	21.73	20.73	19.73	18.73	17.73	16.73	15.73	14.73
14FCS	"A"	32.63	29.80	26.97	25.14	24.31	23.48	22.65	21.82	21.00	20.18	19.36	18.54	17.72
	"B"	14	12	10	8	6	4	2	0	-2	-4	-6	-8	-10
	"C"	24.31	22.90	21.49	20.78	20.07	19.36	18.65	17.94	17.23	16.52	15.81	15.10	14.39
	"D"	24.31	23.31	22.31	21.31	20.31	19.31	18.31	17.31	16.31	15.31	14.31	13.31	12.31
12FCS	"A"	29.80	26.97	25.14	24.31	23.48	22.65	21.82	21.00	20.18	19.36	18.54	17.72	16.90
	"B"	12	10	8	6	4	2	0	-2	-4	-6	-8	-10	-12
	"C"	21.90	20.49	19.78	19.07	18.36	17.65	16.94	16.23	15.52	14.81	14.10	13.39	12.68
	"D"	21.90	20.90	19.90	18.90	17.90	16.90	15.90	14.90	13.90	12.90	11.90	10.90	9.90
10FCS	"A"	26.97	25.14	24.31	23.48	22.65	21.82	21.00	20.18	19.36	18.54	17.72	16.90	16.08
	"B"	10	8	6	4	2	0	-2	-4	-6	-8	-10	-12	-14
	"C"	19.49	18.78	18.07	17.36	16.65	15.94	15.23	14.52	13.81	13.10	12.39	11.68	10.97
	"D"	19.49	18.49	17.49	16.49	15.49	14.49	13.49	12.49	11.49	10.49	9.49	8.49	7.49
9FCS	"A"	25.14	24.31	23.48	22.65	21.82	21.00	20.18	19.36	18.54	17.72	16.90	16.08	15.26
	"B"	9	8	7	6	5	4	3	2	1	0	-1	-2	-3
	"C"	18.28	17.57	16.86	16.15	15.44	14.73	14.02	13.31	12.60	11.89	11.18	10.47	9.76
	"D"	18.28	17.28	16.28	15.28	14.28	13.28	12.28	11.28	10.28	9.28	8.28	7.28	6.28
8FCS	"A"	24.31	23.48	22.65	21.82	21.00	20.18	19.36	18.54	17.72	16.90	16.08	15.26	14.44
	"B"	8	7	6	5	4	3	2	1	0	-1	-2	-3	-4
	"C"	17.07	16.36	15.65	14.94	14.23	13.52	12.81	12.10	11.39	10.68	9.97	9.26	8.55
	"D"	17.07	16.07	15.07	14.07	13.07	12.07	11.07	10.07	9.07	8.07	7.07	6.07	5.07
7FCS	"A"	22.73	21.31	20.48	19.65	18.82	18.00	17.18	16.36	15.54	14.72	13.90	13.08	12.26
	"B"	7	6	5	4	3	2	1	0	-1	-2	-3	-4	-5
	"C"	15.86	15.15	14.44	13.73	13.02	12.31	11.60	10.89	10.18	9.47	8.76	8.05	7.34
	"D"	15.86	14.86	13.86	12.86	11.86	10.86	9.86	8.86	7.86	6.86	5.86	4.86	3.86
6FCS	"A"	21.31	20.48	19.65	18.82	18.00	17.18	16.36	15.54	14.72	13.90	13.08	12.26	11.44
	"B"	6	5	4	3	2	1	0	-1	-2	-3	-4	-5	-6
	"C"	14.66	13.95	13.24	12.53	11.82	11.11	10.40	9.69	8.98	8.27	7.56	6.85	6.14
	"D"	14.66	13.66	12.66	11.66	10.66	9.66	8.66	7.66	6.66	5.66	4.66	3.66	2.66

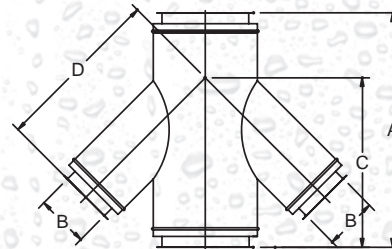

**FCSSW / FCS / FCS-1  
45MT & DL TABLE IN INCHES**

## CORR/GUARD® 45MT & DL TABLE IN METRIC 153mm – 915mm Diameters

		TAP I.D.												
		36	34	32	30	28	26	24	22	20	18	16	14	12
36FCS	"A"	1619	1547	1475	1403	1332	1260	1188	1116	1044	972	901	830	759
	"B"	914	864	813	762	711	660	610	559	508	457	406	356	305
	"C"	1292	1256	1220	1184	1148	1112	1077	1041	1005	969	933	897	861
	"D"	1292	1267	1241	1216	1190	1165	1140	1114	1089	1063	1038	1013	987
34FCS	"A"	1547	1475	1403	1332	1260	1188	1116	1044	972	901	830	759	688
	"B"	864	813	762	711	660	610	559	508	457	406	356	305	254
	"C"	1231	1195	1159	1123	1087	1051	1015	979	943	907	872	836	800
	"D"	1231	1205	1180	1155	1129	1104	1078	1053	1028	1002	977	951	926
32FCS	"A"	1475	1403	1332	1260	1188	1116	1044	972	901	830	759	688	617
	"B"	813	762	711	660	610	559	508	457	406	356	305	254	203
	"C"	1169	1134	1098	1062	1026	990	954	918	882	846	810	774	738
	"D"	1169	1144	1119	1093	1068	1042	1017	992	966	941	915	890	865
30FCS	"A"	1403	1332	1260	1188	1116	1044	972	901	830	759	688	617	546
	"B"	762	711	660	610	559	508	457	406	356	305	254	203	152
	"C"	1108	1072	1036	1000	964	929	893	857	821	785	749	713	677
	"D"	1108	1083	1057	1032	1007	981	956	930	905	880	854	829	803
28FCS	"A"	1332	1260	1188	1116	1044	972	901	829	757	685	613	541	469
	"B"	711	660	610	559	508	457	406	356	305	254	203	152	101
	"C"	1047	1011	975	939	903	867	831	795	759	724	688	652	616
	"D"	1047	1021	996	971	945	920	894	869	844	818	793	767	741
26FCS	"A"	1260	1188	1116	1044	972	901	829	757	685	613	541	469	397
	"B"	660	610	559	508	457	406	356	305	254	203	152	101	50
	"C"	985	950	914	878	842	806	770	734	698	662	626	590	554
	"D"	985	960	935	909	884	858	833	807	782	757	731	705	680
24FCS	"A"	1188	1116	1044	972	901	829	757	685	613	541	469	397	325
	"B"	610	559	508	457	406	356	305	254	203	152	101	50	0
	"C"	924	888	852	816	780	745	709	673	637	601	565	529	493
	"D"	924	899	873	848	823	797	772	746	721	696	671	645	620
22FCS	"A"	1116	1044	972	901	829	757	685	613	541	469	397	325	253
	"B"	559	508	457	406	356	305	254	203	152	101	50	0	0
	"C"	863	827	791	755	719	683	647	611	575	539	503	467	431
	"D"	863	837	812	787	761	736	710	685	660	635	610	585	560
20FCS	"A"	1044	972	901	829	757	685	613	541	469	397	325	253	181
	"B"	508	457	406	356	305	254	203	152	101	50	0	0	0
	"C"	802	766	730	694	658	622	586	550	514	478	442	406	370
	"D"	802	776	751	725	700	675	649	624	598	573	547	522	496
18FCS	"A"	972	901	829	757	685	613	541	469	397	325	253	181	109
	"B"	457	406	356	305	254	203	152	101	50	0	0	0	0
	"C"	740	704	668	632	597	561	525	489	453	417	381	345	309
	"D"	740	715	689	664	639	613	588	563	537	512	487	462	437
16FCS	"A"	901	829	757	685	613	541	469	397	325	253	181	109	37
	"B"	406	356	305	254	203	152	101	50	0	0	0	0	0
	"C"	679	643	607	571	535	500	464	428	392	356	320	284	248
	"D"	679	653	628	603	578	553	527	502	477	452	427	402	377
14FCS	"A"	829	757	685	613	541	469	397	325	253	181	109	37	0
	"B"	356	305	254	203	152	101	50	0	0	0	0	0	0
	"C"	618	582	546	510	474	438	402	366	330	294	258	222	186
	"D"	618	592	567	541	515	490	464	438	413	387	362	336	311
12FCS	"A"	757	685	613	541	469	397	325	253	181	109	37	0	0
	"B"	305	254	203	152	101	50	0	0	0	0	0	0	0
	"C"	556	520	484	448	412	376	340	304	268	232	196	160	124
	"D"	556	531	518	505	493	480	467	454	441	428	415	402	389
10FCS	"A"	685	613	541	469	397	325	253	181	109	37	0	0	0
	"B"	254	203	152	101	50	0	0	0	0	0	0	0	0
	"C"	495	477	459	441	423	405	387	369	351	333	315	297	279
	"D"	495	482	470	457	444	431	418	405	392	379	366	353	340
9FCS	"A"	613	541	469	397	325	253	181	109	37	0	0	0	0
	"B"	203	152	101	50	0	0	0	0	0	0	0	0	0
	"C"	464	446	428	410	392	374	356	338	320	302	284	266	248
	"D"	464	452	439	426	413	400	387	374	361	348	335	322	309
8FCS	"A"	541	469	397	325	253	181	109	37	0	0	0	0	0
	"B"	152	101	50	0	0	0	0	0	0	0	0	0	0
	"C"	434	416	398	380	362	344	326	308	290	272	254	236	218
	"D"	434	421	408	395	382	369	356	343	330	317	304	291	278
7FCS	"A"	469	397	325	253	181	109	37	0	0	0	0	0	0
	"B"	101	50	0	0	0	0	0	0	0	0	0	0	0
	"C"	403	385	367	349	331	313	295	277	259	241	223	205	187
	"D"	403	390	377	364	351	338	325	312	299	286	273	260	247
6FCS	"A"	397	325	253	181	109	37	0	0	0	0	0	0	0
	"B"	50	0	0	0	0	0	0	0	0	0	0	0	0
	"C"	372	354	336	318	300	282	264	246	228	210	192	174	156
	"D"	372	359	346	333	320	307	294	281	268	255	242	229	216

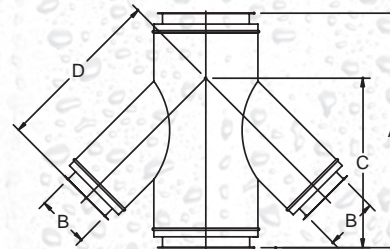

**FCSSW / FCS / FCS-1  
45MT & DL TABLE IN METRIC**

# FCS/FCSSW COMPONENTS 6" – 36" DIAMETERS

## CORR/GUARD® 45MT & DL TABLE IN INCHES 6" – 36" Diameters

		TAP I.D.														
		36	34	32	30	28	26	24	22	20	18	16	14	12	10	
BODY I.D.	36FCS-2	"A" 66.56	63.73	60.91	58.08	55.25	52.42	49.59	46.77	43.94	41.11	40.28	38.63	37.63	35.80	
		"B" 36	34	32	30	28	26	24	22	20	18	16	14	12	10	
		"C" 53.28	51.87	50.45	49.04	47.63	46.21	44.80	43.38	41.97	40.56	39.14	37.73	36.31	34.90	
		"D" 53.28	52.28	51.28	50.28	49.28	48.28	47.28	46.28	45.28	44.28	43.28	42.28	41.28	40.28	
		34	32	30	28	26	24	22	20	18	16	14	12	10	8	
		34FCS-2	"A" 63.73	60.91	58.08	55.25	52.42	49.59	46.77	43.94	41.11	39.28	37.63	36.63	34.80	32.97
		"B" 34	32	30	28	26	24	22	20	18	16	14	12	10	8	
		"C" 50.87	49.45	48.04	46.63	45.21	43.80	42.38	40.97	39.56	38.14	36.73	35.31	33.90	32.49	
		"D" 50.87	49.87	48.87	47.87	46.87	45.87	44.87	43.87	42.87	41.87	40.87	39.87	38.87	37.87	
		32	30	28	26	24	22	20	18	16	14	12	10	8	6	
		32FCS-2	"A" 60.91	58.08	55.25	52.42	49.59	46.77	43.94	41.11	38.28	36.63	35.63	33.80	31.97	31.39
		"B" 32	30	28	26	24	22	20	18	16	14	12	10	8	6	
		"C" 48.45	47.04	45.63	44.21	42.80	41.38	39.97	38.56	37.14	35.73	34.31	32.90	31.49	30.07	
		"D" 48.45	47.45	46.45	45.45	44.45	43.45	42.45	41.45	40.45	39.45	38.45	37.45	36.45	35.45	
		30	28	26	24	22	20	18	16	14	12	10	8	6	6	
		30FCS-2	"A" 58.08	55.25	52.42	49.59	46.77	43.94	41.11	38.28	35.45	34.63	32.80	30.97	30.39	
	"B" 30	28	26	24	22	20	18	16	14	12	10	8	6	6		
	"C" 46.04	44.63	43.21	41.80	40.38	38.97	37.56	36.14	34.73	33.31	31.90	30.49	29.07	29.07		
	"D" 46.04	45.04	44.04	43.04	42.04	41.04	40.04	39.04	38.04	37.04	36.04	35.04	34.04	34.04		
	28	26	24	22	20	18	16	14	12	10	8	6	6	6		
	28FCS-2	"A" 55.25	52.42	49.59	46.77	43.94	41.11	38.28	35.45	33.63	31.80	29.97	29.39	29.39		
	"B" 28	26	24	22	20	18	16	14	12	10	8	6	6	6		
	"C" 43.63	42.21	40.80	39.38	37.97	36.56	35.14	33.73	32.31	30.90	29.49	28.07	28.07	28.07		
	"D" 43.63	42.63	41.63	40.63	39.63	38.63	37.63	36.63	35.63	34.63	33.63	32.63	32.63	32.63		
	26	24	22	20	18	16	14	12	10	8	6	6	6	6		
	26FCS-2	"A" 52.42	49.59	46.77	43.94	41.11	38.28	35.45	32.63	30.80	28.97	28.39	28.39	28.39		
	"B" 26	24	22	20	18	16	14	12	10	8	6	6	6	6		
	"C" 41.21	39.80	38.38	36.97	35.56	34.14	32.73	31.31	29.90	28.49	27.07	27.07	27.07	27.07		
	"D" 41.21	40.21	39.21	38.21	37.21	36.21	35.21	34.21	33.21	32.21	31.21	31.21	31.21	31.21		
	24	22	20	18	16	14	12	10	8	6	6	6	6	6		
	24FCS-2	"A" 49.59	46.77	43.94	41.11	38.28	35.45	32.63	29.80	27.97	27.39	27.39	27.39	27.39		
	"B" 24	22	20	18	16	14	12	10	8	6	6	6	6	6		
	"C" 38.80	37.38	35.97	34.56	33.14	31.73	30.31	28.90	27.49	26.07	26.07	26.07	26.07	26.07		
	"D" 38.80	37.80	36.80	35.80	34.80	33.80	32.80	31.80	30.80	29.80	29.80	29.80	29.80	29.80		
	22	20	18	16	14	12	10	8	6	6	6	6	6	6		
	22FCS-2	"A" 46.77	43.94	41.11	38.28	35.45	32.63	29.80	26.97	26.39	26.39	26.39	26.39	26.39		
	"B" 22	20	18	16	14	12	10	8	6	6	6	6	6	6		
	"C" 36.38	34.97	33.56	32.14	30.73	29.31	27.90	26.49	25.07	25.07	25.07	25.07	25.07	25.07		
	"D" 36.38	35.38	34.38	33.38	32.38	31.38	30.38	29.38	28.38	28.38	28.38	28.38	28.38	28.38		
	20	18	16	14	12	10	8	6	6	6	6	6	6	6		
	20FCS-2	"A" 43.94	41.11	38.28	35.45	32.63	29.80	26.97	24.14	24.14	24.14	24.14	24.14	24.14		
	"B" 20	18	16	14	12	10	8	6	6	6	6	6	6	6		
	"C" 33.97	32.56	31.14	29.73	28.31	26.90	25.49	24.07	24.07	24.07	24.07	24.07	24.07	24.07		
	"D" 33.97	32.97	31.97	30.97	29.97	28.97	27.97	26.97	25.97	24.97	24.97	24.97	24.97	24.97		
	18	16	14	12	10	8	6	6	6	6	6	6	6	6		
	18FCS-2	"A" 41.11	38.28	35.45	32.63	29.80	26.97	24.14	24.14	24.14	24.14	24.14	24.14	24.14		
	"B" 18	16	14	12	10	8	6	6	6	6	6	6	6	6		
	"C" 31.56	30.14	28.73	27.31	25.90	24.49	23.07	23.07	23.07	23.07	23.07	23.07	23.07	23.07		
	"D" 31.56	30.56	29.56	28.56	27.56	26.56	25.56	24.56	23.56	22.56	22.56	22.56	22.56	22.56		
	16	14	12	10	8	6	6	6	6	6	6	6	6	6		
	16FCS-2	"A" 38.28	35.45	32.63	29.80	26.97	24.14	24.14	24.14	24.14	24.14	24.14	24.14	24.14		
	"B" 16	14	12	10	8	6	6	6	6	6	6	6	6	6		
	"C" 29.14	27.73	26.31	24.90	23.49	22.07	22.07	22.07	22.07	22.07	22.07	22.07	22.07	22.07		
	"D" 29.14	28.14	27.14	26.14	25.14	24.14	24.14	24.14	24.14	24.14	24.14	24.14	24.14	24.14		
	14	12	10	8	6	6	6	6	6	6	6	6	6	6		
	14FCS-2	"A" 35.45	32.63	29.80	26.97	24.14	24.14	24.14	24.14	24.14	24.14	24.14	24.14	24.14		
	"B" 14	12	10	8	6	6	6	6	6	6	6	6	6	6		
	"C" 26.73	25.31	23.90	22.49	21.07	21.07	21.07	21.07	21.07	21.07	21.07	21.07	21.07	21.07		
	"D" 26.73	25.73	24.73	23.73	22.73	21.73	20.73	19.73	18.73	17.73	16.73	15.73	14.73	13.73		
	12	10	8	6	6	6	6	6	6	6	6	6	6	6		
	12FCS-2	"A" 32.63	29.80	26.97	24.14	24.14	24.14	24.14	24.14	24.14	24.14	24.14	24.14	24.14		
	"B" 12	10	8	6	6	6	6	6	6	6	6	6	6	6		
	"C" 24.31	22.90	21.49	20.07	20.07	20.07	20.07	20.07	20.07	20.07	20.07	20.07	20.07	20.07		
	"D" 24.31	23.31	22.31	21.31	20.31	19.31	18.31	17.31	16.31	15.31	14.31	13.31	12.31	11.31		
	10	8	6	6	6	6	6	6	6	6	6	6	6	6		
	10FCS-2	"A" 29.80	26.97	24.14	24.14	24.14	24.14	24.14	24.14	24.14	24.14	24.14	24.14	24.14		
	"B" 10	8	6	6	6	6	6	6	6	6	6	6	6	6		
	"C" 21.90	20.49	19.07	19.07	19.07	19.07	19.07	19.07	19.07	19.07	19.07	19.07	19.07	19.07		
	"D" 21.90	20.90	19.90	18.90	17.90	16.90	15.90	14.90	13.90	12.90	11.90	10.90	9.90	8.90		
	8	6	6	6	6	6	6	6	6	6	6	6	6	6		
	8FCS-2	"A" 26.97	24.14	24.14	24.14	24.14	24.14	24.14	24.14	24.14	24.14	24.14	24.14	24.14		
	"B" 8	6	6	6	6	6	6	6	6	6	6	6	6	6		
	"C" 19.49	18.07	18.07	18.07	18.07	18.07	18.07	18.07	18.07	18.07	18.07	18.07	18.07	18.07		
	"D" 19.49	18.49	17.49	16.49	15.49	14.49	13.49	12.49	11.49	10.49	9.49	8.49	7.49	6.49		
	6	6	6	6	6	6	6	6	6	6	6	6	6	6		
	6FCS-2	"A" 24.14	24.14	24.14	24.14	24.14	24.14	24.14	24.14	24.14	24.14	24.14	24.14	24.14		
	"B" 6	6	6	6	6	6	6	6	6	6	6	6	6	6		
	"C" 17.07	17.07	17.07	17.07	17.07	17.07	17.07	17.07	17.07	17.07	17.07	17.07	17.07	17.07		
	"D" 17.07	17.07	17.07	17.07	17.07	17.07	17.07	17.07	17.07	17.07	17.07	17.07	17.07	17.07		

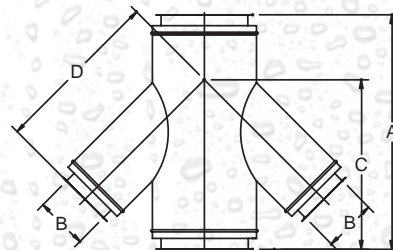

**FCS-2**  
**45MT & DL TABLE IN INCHES**

## CORR/GUARD® 45MT & DL TABLE IN METRIC 153mm – 915mm Diameters

		TAP I.D.													
		36	34	32	30	28	26	24	22	20	18	16	14	12	10
36FCS-2	"A"	1691	1619	1547	1475	1403	1331	1260	1188	1116	1044	1023	981	956	909
	"B"	914	864	813	762	711	660	610	559	508	457	406	356	305	254
	"C"	1353	1317	1281	1246	1210	1174	1138	1102	1066	1030	994	958	922	886
	"D"	1353	1328	1303	1277	1252	1226	1201	1176	1150	1125	1099	1074	1049	1023
34FCS-2	"A"	1619	1547	1475	1403	1331	1260	1188	1116	1044	998	956	930	884	837
	"B"	864	813	762	711	660	610	559	508	457	406	356	305	254	203
	"C"	1292	1256	1220	1184	1148	1113	1076	1041	1005	969	933	897	861	825
	"D"	1292	1267	1241	1216	1190	1165	1140	1114	1089	1063	1038	1013	987	962
32FCS-2	"A"	1547	1475	1403	1331	1260	1188	1116	1044	972	930	905	859	812	797
	"B"	813	762	711	660	610	559	508	457	406	356	305	254	203	152
	"C"	1231	1196	1159	1123	1087	1051	1015	979	943	908	871	836	800	764
	"D"	1231	1205	1180	1154	1129	1104	1078	1053	1027	1002	977	951	926	900
30FCS-2	"A"	1475	1403	1331	1260	1188	1116	1044	972	900	880	833	787	772	797
	"B"	762	711	660	610	559	508	457	406	356	305	254	203	152	152
	"C"	1169	1134	1098	1062	1026	990	954	918	882	846	810	774	738	738
	"D"	1169	1144	1119	1093	1068	1042	1017	992	966	941	915	890	865	865
28FCS-2	"A"	1403	1331	1260	1188	1116	1044	972	900	854	808	761	747	747	747
	"B"	711	660	610	559	508	457	406	356	305	254	203	152	152	152
	"C"	1108	1072	1036	1000	964	929	893	857	821	785	749	713	713	713
	"D"	1108	1083	1057	1032	1007	981	956	930	905	880	854	829	829	829
26FCS-2	"A"	1331	1260	1188	1116	1044	972	900	829	782	736	721	721	721	721
	"B"	660	610	559	508	457	406	356	305	254	203	152	152	152	152
	"C"	1047	1011	975	939	903	867	831	795	759	724	688	688	688	688
	"D"	1047	1021	996	971	945	920	894	869	844	818	793	793	793	793
24FCS-2	"A"	1260	1188	1116	1044	972	900	829	757	710	696	696	696	696	696
	"B"	610	559	508	457	406	356	305	254	203	152	152	152	152	152
	"C"	986	949	914	878	842	806	770	734	698	662	662	662	662	662
	"D"	986	960	935	909	884	859	833	808	782	757	757	757	757	757
22FCS-2	"A"	1188	1116	1044	972	900	829	757	685	670	670	670	670	670	670
	"B"	559	508	457	406	356	305	254	203	152	152	152	152	152	152
	"C"	924	888	852	816	781	744	709	673	637	637	637	637	637	637
	"D"	924	899	873	848	822	797	772	746	721	721	721	721	721	721
20FCS-2	"A"	1116	1044	972	900	829	757	685	613	613	613	613	613	613	613
	"B"	508	457	406	356	305	254	203	152	152	152	152	152	152	152
	"C"	863	827	791	755	719	683	647	611	611	611	611	611	611	611
	"D"	863	837	812	787	761	736	710	685	685	685	685	685	685	685
18FCS-2	"A"	1044	972	900	829	757	685	613	613	613	613	613	613	613	613
	"B"	457	406	356	305	254	203	152	152	152	152	152	152	152	152
	"C"	802	766	730	694	658	622	586	586	586	586	586	586	586	586
	"D"	802	776	751	725	700	675	649	649	649	649	649	649	649	649
16FCS-2	"A"	972	900	829	757	685	613	613	613	613	613	613	613	613	613
	"B"	406	356	305	254	203	152	152	152	152	152	152	152	152	152
	"C"	740	704	668	632	597	561	561	561	561	561	561	561	561	561
	"D"	740	715	689	664	639	613	613	613	613	613	613	613	613	613
14FCS-2	"A"	900	829	757	685	613	613	613	613	613	613	613	613	613	613
	"B"	356	305	254	203	152	152	152	152	152	152	152	152	152	152
	"C"	679	643	607	571	535	535	535	535	535	535	535	535	535	535
	"D"	679	654	628	603	577	577	577	577	577	577	577	577	577	577
12FCS-2	"A"	829	757	685	613	613	613	613	613	613	613	613	613	613	613
	"B"	305	254	203	152	152	152	152	152	152	152	152	152	152	152
	"C"	617	582	546	510	510	510	510	510	510	510	510	510	510	510
	"D"	617	592	567	541	541	541	541	541	541	541	541	541	541	541
10FCS-2	"A"	757	685	613	613	613	613	613	613	613	613	613	613	613	613
	"B"	254	203	152	152	152	152	152	152	152	152	152	152	152	152
	"C"	556	520	484	484	484	484	484	484	484	484	484	484	484	484
	"D"	556	531	505	505	505	505	505	505	505	505	505	505	505	505
8FCS-2	"A"	685	613	613	613	613	613	613	613	613	613	613	613	613	613
	"B"	203	152	152	152	152	152	152	152	152	152	152	152	152	152
	"C"	495	459	470	470	470	470	470	470	470	470	470	470	470	470
	"D"	495	470	470	470	470	470	470	470	470	470	470	470	470	470
6FCS-2	"A"	613	613	613	613	613	613	613	613	613	613	613	613	613	613
	"B"	152	152	152	152	152	152	152	152	152	152	152	152	152	152
	"C"	434	434	434	434	434	434	434	434	434	434	434	434	434	434
	"D"	434	434	434	434	434	434	434	434	434	434	434	434	434	434

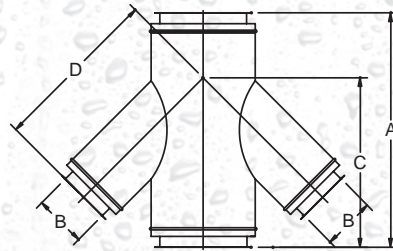

**FCS-2**  
**45MT & DL TABLE IN METRIC**



— 800-835-2830 —

P.O. BOX 1138 • WICHITA, KANSAS 67201 • (316) 943-2351 • FAX (316) 771-4168 • [info@metal-fabinc.com](mailto:info@metal-fabinc.com) • [www.metal-fabcommercial.com](http://www.metal-fabcommercial.com)